

Gyártmánykatalógus  
fogorvosi rendelők számára  
HU





## Gyár NTI-Kahla

Az NTI-Kahla vállalat fogorvosi fúrók, csiszolókorongok gyártója és az egész világra kiterjedő forgalmazója. Kahla, a cég székhelye közvetlenül Thüringia szívében fekszik, Jénától délre 10 km távolságra. Németországban az NTI külszolgálatos szaktanácsadók révén közvetlenül fogorvosokat és fogtechnikusokat lát el. A föld 90 országában a forgalmazás tapasztalt partnerek segítségével történik.

A katalógus szerzői jogi védelem alatt áll. A szerzői jogi törvény szűk határain kívül történő bármilyen felhasználás az NTI-Kahla GmbH vállalat írásbeli engedélye nélkül tilos és büntetendő. Ez különösen érvényes a sokszorosításra, fordításokra, mikrofilmre való felvételre és elektronikus rendszerekben történő tárolásra és feldolgozásra.

A szükségessé vált gyártmány- és színvonatokozású változtatásokra, valamint a nyomdahibákra vonatkozó jog fenntartva.

© NTI-Kahla GmbH Rotary Dental Instruments • Printed in Germany

- |   |         |  |
|---|---------|--|
|    | 4, 5    | <b>ABACUS</b> ® gyémántcsiszolók   |
|    | 6 - 15  | Gyémánt - csiszolószerszámok FGL, FGM, FG, RA<br>Kéztónás gyémánt csiszolók                    |
|    | 16, 17  | Gyémántcsiszolók vezetőcsúccsal<br><b>LazyBur / Easy Chamfer / InPrep</b>                      |
|    | 17, 18  | <b>Z-Cut</b> gyémántcsiszolók  |
|    | 18, 19  | <b>TURBO</b> gyémántcsiszolók  |
|    | 20 - 22 | Egyoldalú gyémánt csiszoló csík<br><b>ProxyStrip</b>   |
|    | 22      | <b>Kiddies</b> Gyermekeknek kifejlesztett, a minimális invazív                                 |
|   | 23      | Koronafelvágó<br><b>MF-Cut</b> Multifunkcionális felvágóeszközök                               |
|  | 24 - 28 | Keményfém fúrók<br>Tömés- és ragasztóanyag eltávolító<br>Finírozók<br>Fogszabályozási eszközök |
|  | 29      | <b>NTi Endo Clean</b> - Endodonciás eszközök   |
|  | 30 - 35 | Sebészeti fúrók<br><b>Trepánfúró</b><br><b>Pilótafúró / Tissue Trimmer</b>                     |
|  | 36 - 38 | Polírozó, <b>DiaGloss, FlexiPol, CeraGlaze, CeraShine</b>                                      |
|  | 38, 39  | Prevenációs polírozók és kefék   |
|  | 40, 41  | Gyökércsap felépítőrendszerek<br><b>HeadMaster</b> , kúpos<br><b>HeadMaster</b> , hengeres     |
|   | 42, 43  | Fordulatszámra vonatkozó ajánlatok   |



**Z368  
(257)**  
Csepp



Átmérő mérete 1/10 mm	020	023	
Hossz mm-ben	5,5	5,0	

5	REF			
	Z368-	020	023	C-FG
	Z368-	020		M-FG
	Z368-	020	023	F-FG



**Z379  
(277)**  
Tojásdad



Átmérő mérete 1/10 mm	023		
Hossz mm-ben	4,2		

5	REF			
	Z379-	023		C-FG
	Z379-	023		F-FG



**Z801  
(001)**  
Gömbölyű

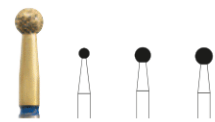

Átmérő mérete 1/10 mm	014	021	023	
Hossz mm-ben	-	-	-	

5	REF				
	Z801-	014	021	023	C-FG
	Z801-	014	021		M-FG
	Z801-	014	021		F-FG



**Z811  
(038)**  
Kettős kúp



Átmérő mérete 1/10 mm	033		
Hossz mm-ben	4,2		

5	REF			
	Z811-	033		C-FG



**Z830L  
(239)**  
Körte, hosszú

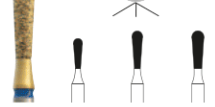

Átmérő mérete 1/10 mm	012	014	016	
Hossz mm-ben	4,0	5,0	5,0	

5	REF				
	Z830L-	012	014	016	C-FG
	Z830L-	012	014	016	M-FG
	Z830L-	012			F-FG



**Z835KR  
(156)**  
Henger,  
gömbölyű munkaél



Átmérő mérete 1/10 mm	012		
Hossz mm-ben	4,5		

5	REF			
	Z835KR-	012		C-FG
	Z835KR-	012		M-FG



**Z837KR  
(158)**  
Henger,  
gömbölyű munkaél



Átmérő mérete 1/10 mm	014		
Hossz mm-ben	8,3		

5	REF			
	Z837KR-	014		C-FG
	Z837KR-	014		M-FG



**Z845KR  
(544)**  
Henger,  
gömbölyű munkaél

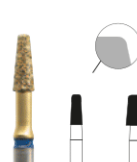

Átmérő mérete 1/10 mm	016	025	
Hossz mm-ben	4,0	4,0	

5	REF			
	Z845KR-		025	C-FG
	Z845KR-	016		M-FG



**Z846KR  
(545)**  
Henger,  
gömbölyű munkaél



Átmérő mérete 1/10 mm	016		
Hossz mm-ben	6,0		

5	REF			
	Z846KR-	016		M-FG



**Z847KR  
(546)**  
Kúp,  
gömbölyű munkaél



Átmérő mérete 1/10 mm	016	018	
Hossz mm-ben	8,0	8,0	

5	REF			
	Z847KR-	016	018	C-FG



**Z847  
(172)**  
Kúp, lapos



Átmérő mérete 1/10 mm	014	016	
Hossz mm-ben	8,0	8,0	

5	REF			
	Z847-	014	016	C-FG



**Z848  
(173)**  
Kúp, lapos



Átmérő mérete 1/10 mm	018		
Hossz mm-ben	10,0		

5	REF			
	Z848-	018		C-FG



**Z850  
(199)**  
Kúp, gömbölyű



Átmérő mérete 1/10 mm	012	014	016	
Hossz mm-ben	10,0	10,0	10,0	

5	REF				
	Z850-	012	014	016	C-FG
	Z850-	012	014		M-FG
	Z850-	012			F-FG



**Z855  
(197)**  
Kúp, gömbölyű



Átmérő mérete 1/10 mm	025		
Hossz mm-ben	7,0		

5	REF			
	Z855-	025		C-FG



**Z856L  
(201)**  
Kúp, gömbölyű,  
hosszú



Átmérő mérete 1/10 mm	018		
Hossz mm-ben	9,0		

5	REF			
	Z855-	018		C-FG



**Z856 (198)**  
Kúp, gömbölyű

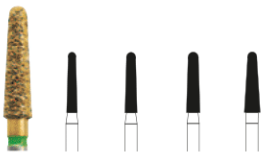

Átmérő mérete 1/10 mm	014	016	018	021		
Hossz mm-ben	8,0	8,0	8,0	8,0		
5	REF					
	Z856-	014	016	018	021	C-FG



**Z858 (165)**  
Kúp, csúcsos



Átmérő mérete 1/10 mm	014		
Hossz mm-ben	8,0		
5	REF		
	Z858-	014	C-FG



**Z862 (249)**  
Láng



Átmérő mérete 1/10 mm	014		
Hossz mm-ben	8,0		
5	REF		
	Z862-	014	C-FG



**Z863 (250)**  
Láng



Átmérő mérete 1/10 mm	012	016		
Hossz mm-ben	10,0	10,0		
5	REF			
	Z863-	012	016	C-FG
	Z863-	012	016	M-FG
	Z863-	012	016	F-FG



**Z877K (297)**  
Torpedó, kúpos



Átmérő mérete 1/10 mm	012	016		
Hossz mm-ben	6,0	6,0		
5	REF			
	Z877K-	012	016	C-FG
	Z877K-	016		F-FG



**Z878 (289)**  
Torpedó



Átmérő mérete 1/10 mm	010	012	014		
Hossz mm-ben	8,0	8,0	8,0		
5	REF				
	Z878-	012	014	C-FG	
	Z878-	010	012	014	M-FG
	Z878-	010	012	014	F-FG



**Z878K (298)**  
Torpedó, kúpos

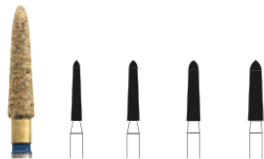

Átmérő mérete 1/10 mm	014	016	018	020	022		
Hossz mm-ben	8,0	8,0	8,0	8,0	8,0		
5	REF						
	Z878K-	014	016	018	020	022	C-FG
	Z878K-	014	016				M-FG
	Z878K-	016			022		F-FG



**Z879 (290)**  
Torpedó



Átmérő mérete 1/10 mm	012	014		
Hossz mm-ben	10,0	10,0		
5	REF			
	Z879	012	014	C-FG
	Z879	012	014	M-FG
	Z879	012	014	F-FG



**Z880 (140)**  
Henger, gömbölyű



Átmérő mérete 1/10 mm	012		
Hossz mm-ben	6,0		
5	REF		
	Z880-	012	C-FG
	Z880-	012	M-FG



**Z879K (299)**  
Torpedó, kúpos

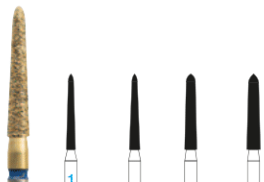

Átmérő mérete 1/10 mm	012	014	016	018		
Hossz mm-ben	10,0	10,0	10,0	10,0		
5	REF					
	Z879K-	012	014	016	018	C-FG
	Z879K-	012	014	016		M-FG
	Z879K-	012	014	016		F-FG



**Z881 (141)**  
Henger, gömbölyű



Átmérő mérete 1/10 mm	014	016		
Hossz mm-ben	8,0	8,0		
5	REF			
	Z881-	014	016	C-FG
	Z881-	014		M-FG
	Z881-	014	016	F-FG



**Z909 (068)**  
Abroncs



Átmérő mérete 1/10 mm	040		
Hossz mm-ben	1,6		
5	REF		
	Z909-	040	C-FG

ABACUS® TURBO gyémánt eszközök



**Z830L (239)**  
Körte, hosszú



Átmérő mérete 1/10 mm	012	014		
Hossz mm-ben	4,0	5,0		
5	REF			
	Z830L-	012	014	TC-FG



**Z850 (199)**  
Kúp, gömbölyű



Átmérő mérete 1/10 mm	016		
Hossz mm-ben	10,0		
5	REF		
	Z850-	016	TC-FG



**Z863 (250)**  
Láng



Átmérő mérete 1/10 mm	016		
Hossz mm-ben	10,0		
5	REF		
	Z863-	016	TC-FG



**Z879 (290)**  
Torpedó



Átmérő mérete 1/10 mm	014		
Hossz mm-ben	8,0		
5	REF		
	Z879-	014	TC-FG



**368  
(257)**

Csepp

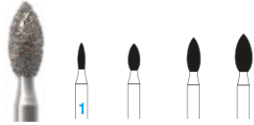

Átmérő mérete 1/10 mm	010	016	018	023	
Hossz mm-ben	3,5	3,5	4,5	5,0	

REF						
368-	010	016	018	023	M-FG	
■	368-	016	018	023	SC-FG	
■	368-	016	018	023	C-FG	
■	368-	010	016	018	023	F-FG
■	368-	010	016	018	023	SF-FG
■	368-	016	018	023	UF-FG	
■	368-		023		M-FGL	
■	368-		023		F-FGL	
■	368-	016			M-RA	



**379  
(277)**

Tojásdad



Átmérő mérete 1/10 mm	012	014	016	018	023	029	
Hossz mm-ben	3,0	3,0	3,2	3,3	4,5	5,5	

REF								
379-	012	014	016	018	023	029	M-FG	
■	379-	014	016	018	023	029	SC-FG	
■	379-	012	014	016	018	023	029	C-FG
■	379-	012	014	016	018	023	029	F-FG
■	379-	012	014	016	018	023	029	SF-FG
■	379-		016	018	023			UF-FG
■	379-			023				M-FGL
■	379-			023				F-FGL
■	379-			023				SF-FGL

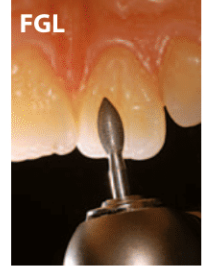
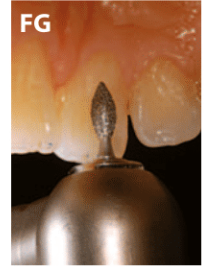

**369  
(263)**

Csepp



Átmérő mérete 1/10 mm	025	
Hossz mm-ben	5,5	

REF			
369-	025	M-FG	
■	369-	025	C-FG
■	369-	025	F-FG
■	369-	025	SF-FG



**370  
(507)**

Speciális alakú



Átmérő mérete 1/10 mm	023	
Hossz mm-ben	5,5	

REF			
370-	023	C-FG	
■	370-	023	F-FG
■	370-	023	SF-FG



**390  
(274)**

Lövedék



Átmérő mérete 1/10 mm	016	
Hossz mm-ben	3,5	

REF			
390-	016	M-FG	
■	390-	016	C-FG
■	390-	016	F-FG
■	390-	016	SF-FG



**392  
(465)**

Fogközi



Átmérő mérete 1/10 mm	016	
Hossz mm-ben	5,0	

REF			
392-	016	M-FGM	
■	392-	016	M-FG
■	392-	016	F-FG
■	392-	016	SF-FG



**801  
(001)**

Gömbölyű

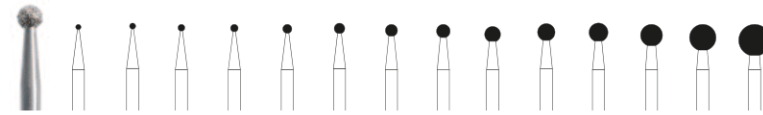

Átmérő mérete 1/10 mm	007	008	009	010	012	014	016	018	021	023	025	029	035	042	
Hossz mm-ben															

REF																
801-					012	014		018							M-FGM	
■	801-	007	008	009	010	012	014	016	018	021	023	025	029	035	042	M-FG
■	801-				012	014	016	018	021	023	025	029	035	042	C-FG	
■	801-	007	008	009	010	012	014	016	018	021	023	025	029	035	F-FG	
■	801-				012	014	016	018	021	023	025	029	035		SF-FG	
■	801-			010	012	014	016	018		023					M-FGXL	
■	801-				014	016	018		023		029				SC-FGXL	
■	801-				014	016	018		023						C-FGXL	
■	801-			010	012	014	016	018	021	023	025	029	035	042	M-RA	



**392A  
(465)**

Fogközi



Átmérő mérete 1/10 mm	016	
Hossz mm-ben	3,5	

REF			
392A-	016	M-FG	
■	392A-	016	F-FG



**801L  
(697)**

Gömbölyű, hosszú

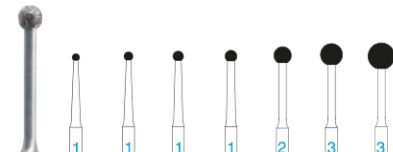

Átmérő mérete 1/10 mm	010	012	014	016	023	029	035	
Hossz mm-ben								

REF									
801L-	010	012	014	016	023	029	035	M-FG	
■	801L-		014	016	023	029		SC-FG	
■	801L-	010	012	014	016	023	029	035	C-FG



**802  
(002)**

Gömbölyű, fejjel

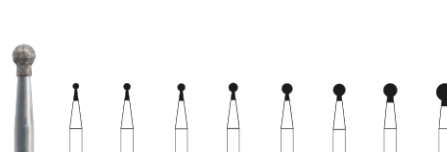

Átmérő mérete 1/10 mm	008	009	010	012	014	016	018	023	
Hossz mm-ben	2,4	2,4	2,4	2,4	2,4	2,4	2,4	3,2	

REF									
802-	008	009	010	012	014	016	018	023	M-FG
■	802-				014	016	018		SC-FG
■	802-			012	014	016	018	023	C-FG
■	802-				014	016	018		F-FG

M	gyűrű nélküli közepes	107-126 μm	ISO 524	■	C	zöld gyűrű	druva	151 μm	ISO 534	■	SF	sárga gyűrű	különösen finom	20 μm	ISO 504		
■	SC	fekete gyűrű	különösen durva	181 μm	ISO 544	■	F	piros gyűrű	finom	40 μm	ISO 514	□	UF	fehér gyűrű	ultrafinom	15 μm	ISO 494



**805  
(010)**

Fordított kúp



Átmérő mérete 1/10 mm	008	009	010	012	014	016	018	021	023	
Hossz mm-ben	1,0	1,0	1,0	1,2	1,6	1,6	1,6	1,9	2,5	

REF

	805-	008	009	010	012	014	016	018	021	023	M-FG
■	805-					014	016	018	021		SC-FG
■	805-				012	014	016	018	021		C-FG
■	805-					014					F-FG
■	805-			010	012	014	016				M-RA



**806  
(019)**

Kúp,  
hosszabítással

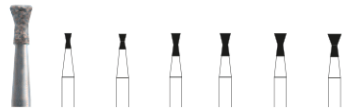

Átmérő mérete 1/10 mm	009	010	012	014	016	018	
Hossz mm-ben	2,0	2,0	3,0	3,0	3,0	3,0	

REF

	806-		010					M-FGM
	806-	009	010	012	014	016	018	M-FG
■	806-				014	016	018	SC-FG
■	806-		010	012	014	016	018	C-FG



**807  
(225)**

Fordított kúp



Átmérő mérete 1/10 mm	010	012	014	016	018	021	023	
Hossz mm-ben	3,0	3,5	3,5	4,0	5,0	5,0	6,0	

REF

	807-		010	012	014	016	018	021	023	M-FG
■	807-					016	018			SC-FG
■	807-			012	014	016	018	021		C-FG



**807L  
(226)**

Fordított kúp,  
hosszú



Átmérő mérete 1/10 mm	018	
Hossz mm-ben	7,0	

REF

	807L-	018	M-FG
--	-------	-----	------



**808  
(014)**

Fordított kúp



Átmérő mérete 1/10 mm	018	023	
Hossz mm-ben	0,7	0,8	

REF

	808-	018	023	M-FG
■	808-	018		C-FG



**811  
(038)**

Kettős kúp

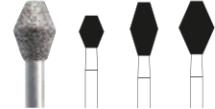

Átmérő mérete 1/10 mm	033	037	047	
Hossz mm-ben	4,4	7,0	7,0	

REF

	811-	033	037	047	M-FG
■	811-	033	037	047	SC-FG
■	811-	033	037	047	C-FG



**813  
(032)**

Diabolo csiszoló



Átmérő mérete 1/10 mm	010	012	014	016	018	
Hossz mm-ben	1,5	1,5	1,5	2,0	2,0	

REF

	813-	010	012	014	016	018	M-FG
■	813-					018	SC-FG
■	813-		012	014	016	018	C-FG



**813L  
(523)**

Hosszú diabolo  
csiszoló



Átmérő mérete 1/10 mm	014	016	
Hossz mm-ben	3,0	3,0	

REF

	813L-	014	016	M-FG
■	813L-	014	016	C-FG



**817  
(041)**

Kerék



Átmérő mérete 1/10 mm	047	
Hossz mm-ben	0,5	

REF

	817-	047	M-FG
■	817-	047	C-FG



**815  
(040)**

Kerék

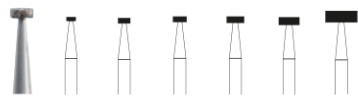

Átmérő mérete 1/10 mm	012	016	018	023	027	042	
Hossz mm-ben	0,5	0,7	0,7	0,8	1,0	1,5	

REF

	815-	012	016	018		027		M-FG
■	815-			018	023	027	042	C-FG



**818  
(042)**

Kerék

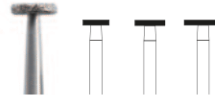

Átmérő mérete 1/10 mm	035	040	050	
Hossz mm-ben	0,7	0,7	0,7	

REF

	818-	035	040	050	M-FG
■	818-	035	040	050	C-FG

M	gyűrű nélkül	közepes	107-126 μm	ISO 524	■	C	zöld gyűrű	druva	151 μm	ISO 534	■	SF	sárga gyűrű	különösen finom	20 μm	ISO 504	
■	SC	fekete gyűrű	különösen durva	181 μm	ISO 544	■	F	piros gyűrű	finom	40 μm	ISO 514	□	UF	fehér gyűrű	ultrafinom	15 μm	ISO 494



**820  
(043)**  
Kerék



Átmérő mérete 1/10 mm	040
Hossz mm-ben	2,0
REF	
<b>820-</b>	<b>040 M-FG</b>



**822  
(237)**  
Körte



Átmérő mérete 1/10 mm	008	009	010	012
Hossz mm-ben	2,0	2,0	2,0	3,0
REF				
<b>822-</b>	<b>008</b>	<b>009</b>	<b>010</b>	<b>012 M-FG</b>
<b>822-</b>				<b>012 SC-FG</b>
<b>822-</b>	<b>008</b>	<b>009</b>	<b>010</b>	<b>012 C-FG</b>
<b>822-</b>			<b>010</b>	<b>012 F-FG</b>



**825  
(304)**  
Lence



Átmérő mérete 1/10 mm	018	023	025	040	050
Hossz mm-ben	0,8	0,9	0,9	1,5	1,5
REF					
<b>825-</b>	<b>018</b>	<b>023</b>	<b>025</b>	<b>040</b>	<b>050 M-FG</b>



**828  
(054)**  
Mélységjelölő

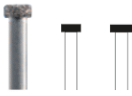

Átmérő mérete 1/10 mm	026	030
Hossz mm-ben	1,0	1,0
REF		
<b>828-</b>	<b>026</b>	<b>030 M-FG</b>
Vágási mélység T mm	0,5	0,7



**830  
(238)**  
Körte



Átmérő mérete 1/10 mm	008	009	010	012	014	016	018	021
Hossz mm-ben	2,5	2,7	2,7	2,7	2,7	2,7	2,7	5,1
REF								
<b>830-</b>	<b>008</b>	<b>009</b>	<b>010</b>	<b>012</b>	<b>014</b>	<b>016</b>	<b>018</b>	<b>021 M-FG</b>
<b>830-</b>				<b>012</b>	<b>014</b>	<b>016</b>	<b>018</b>	<b>SC-FG</b>
<b>830-</b>			<b>010</b>	<b>012</b>	<b>014</b>	<b>016</b>	<b>018</b>	<b>021 C-FG</b>
<b>830-</b>	<b>008</b>	<b>009</b>	<b>010</b>	<b>012</b>	<b>014</b>		<b>018</b>	<b>021 F-FG</b>
<b>830-</b>	<b>008</b>			<b>012</b>				<b>SF-FG</b>



**830L  
(239)**  
Körte, hosszú



Átmérő mérete 1/10 mm	010	012	014	016	018	021	025
Hossz mm-ben	4,0	4,0	5,0	5,0	5,0	5,0	7,0
REF							
<b>830L-</b>	<b>010</b>	<b>012</b>	<b>014</b>	<b>016</b>	<b>018</b>	<b>021</b>	<b>025 M-FG</b>
<b>830L-</b>			<b>014</b>	<b>016</b>	<b>018</b>	<b>021</b>	<b>025 SC-FG</b>
<b>830L-</b>		<b>012</b>	<b>014</b>	<b>016</b>	<b>018</b>	<b>021</b>	<b>025 C-FG</b>
<b>830L-</b>		<b>012</b>	<b>014</b>	<b>016</b>	<b>018</b>		<b>F-FG</b>
<b>830L-</b>			<b>014</b>	<b>016</b>		<b>021</b>	<b>SF-FG</b>



**833  
(466)**  
Rágófelszín kontúrozó

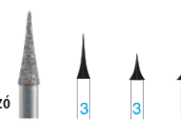

Átmérő mérete 1/10 mm	018	021	031
Hossz mm-ben	5,9	3,5	3,5
REF			
<b>833-</b>	<b>018</b>	<b>021</b>	<b>031 M-FG</b>
<b>833-</b>	<b>018</b>	<b>021</b>	<b>031 F-FG</b>
<b>833-</b>	<b>018</b>	<b>021</b>	<b>031 SF-FG</b>



**834  
(552)**  
Mélységjelölő

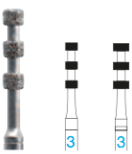

Átmérő mérete 1/10 mm	016	021
Hossz mm-ben	6,0	6,0
REF		
<b>834-</b>	<b>016</b>	<b>021 M-FG</b>
Vágási mélység T mm	0,3	0,5



**868A  
(560)**  
Mélységjelölő

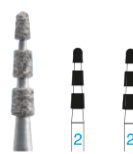

Átmérő mérete 1/10 mm	018	021
Hossz mm-ben	8,0	8,0
REF		
<b>868A-</b>	<b>018</b>	<b>021 M-FG</b>
Vágási mélység T mm	0,3	0,4

**Teljes kerámia preparáció**

**VKP  
834RL  
(301)**  
Mélységjelölő

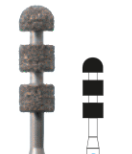

Átmérő mérete 1/10 mm	027
Hossz mm-ben	8,0
REF	
<b>834RL-</b>	<b>027 M-FG</b>
Vágási mélység T mm	0,8

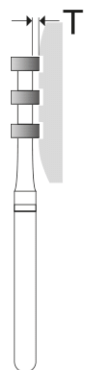

**834A  
(242)**  
Mélységjelölő



Átmérő mérete 1/10 mm	031
Hossz mm-ben	3,5
REF	
<b>834A-</b>	<b>031 M-FG</b>
Vágási mélység T mm	1,0



**MADC  
Mélységjelölő**

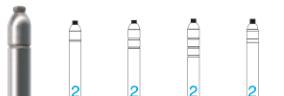

Átmérő mérete 1/10 mm	009	009	009	009
Hossz mm-ben	0,3	0,4	0,5	0,6
REF				
<b>MADC03-</b>	<b>009</b>			<b>M-FG</b>
<b>MADC04-</b>		<b>009</b>		<b>M-FG</b>
<b>MADC05-</b>			<b>009</b>	<b>M-FG</b>
<b>MADC06-</b>				<b>009 M-FG</b>
Vágási mélység T mm	0,3	0,4	0,5	0,6
⊖ opt. 40.000 - 85.000 rpm				



**MADC  
Mélységjelölő**



Átmérő mérete 1/10 mm	009	009	009	009
Hossz mm-ben	0,8	1,0	1,5	2,0
REF				
<b>MADC08-</b>	<b>009</b>			<b>M-FG</b>
<b>MADC10-</b>		<b>009</b>		<b>M-FG</b>
<b>MADC15-</b>			<b>009</b>	<b>M-FG</b>
<b>MADC20-</b>				<b>009 M-FG</b>
Vágási mélység T mm	0,8	1,0	1,5	2,0
⊖ opt. 40.000 - 85.000 rpm				

by Dr Mark J. Caldwell

M gyűrű nélkül közepes 107-126 µm ISO 524	■ C zöld gyűrű druva 151 µm ISO 534	■ SF sárga gyűrű különösen finom 20 µm ISO 504
■ SC fekete gyűrű különösen durva 181 µm ISO 544	■ F piros gyűrű finom 40 µm ISO 514	□ UF fehér gyűrű ultrafinom 15 µm ISO 494





**835  
(107)**

Henger



Átmérő mérete 1/10 mm	007	008	009	010	012	014	016	018	
Hossz mm-ben	3,0	3,0	3,0	4,0	4,0	4,0	4,0	4,0	

REF									
	835-		008		010		014		M-FGM
■	835-				010				C-FGM
	835-	007	008	009	010	012	014	016	M-FG
■	835-				010	012	014	016	SC-FG
■	835-		009	010	012	014	016	018	C-FG
■	835-			010	012	014			F-FG
■	835-			010	012	014	016		M-RA



**835KR  
(156)**

Henger,  
gömbölyű munkaél

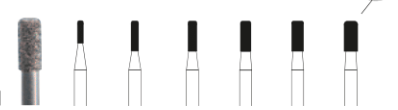

Átmérő mérete 1/10 mm	008	010	012	014	016	018	
Hossz mm-ben	3,0	4,0	4,0	4,0	4,0	4,0	

REF								
	835KR-	008	010	012	014	016	018	M-FG
■	835KR-				014			SC-FG
■	835KR-		010	012	014	016	018	C-FG
■	835KR-			012	014			F-FG



**836  
(110)**

Henger

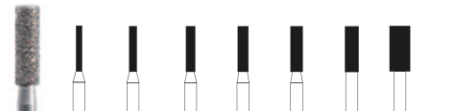

Átmérő mérete 1/10 mm	008	010	012	014	016	018	027
Hossz mm-ben	6,0	6,0	6,0	6,0	6,0	6,0	6,0

REF									
■	836-				014				SC-FGM
	836-	008	010	012	014	016	018		M-FG
■	836-			012	014	016	027		SC-FG
■	836-		010	012	014	016	018		C-FG
■	836-		010	012					F-FG



**836KR  
(157)**

Henger,  
gömbölyű munkaél



Átmérő mérete 1/10 mm	008	010	012	014	016	018
Hossz mm-ben	6,0	6,0	6,0	6,0	6,0	6,0

REF								
	836KR-	008	010	012	014	016		M-FG
■	836KR-				014			SC-FG
■	836KR-		010	012	014	016	018	C-FG
■	836KR-	008	010	012	014			F-FG



**837  
(111)**

Henger



Átmérő mérete 1/10 mm	010	012	014	016	018
Hossz mm-ben	8,0	8,0	8,0	8,0	8,0

REF							
	837-	010	012	014	016	018	M-FG
■	837-		012	014	016	018	SC-FG
■	837-	010	012	014	016	018	C-FG
■	837-		012	014			F-FG



**837KR  
(158)**

Henger,  
gömbölyű munkaél



Átmérő mérete 1/10 mm	010	012	014	016	018
Hossz mm-ben	8,0	8,0	8,0	8,0	8,0

REF							
	837KR-	010	012	014	016	018	M-FG
■	837KR-		012	014	016	018	SC-FG
■	837KR-	010	012	014	016	018	C-FG
■	837KR-	010	012	014	016		F-FG



**837L  
(112)**

Henger, hosszú



Átmérő mérete 1/10 mm	010	012	014	016	018
Hossz mm-ben	10,0	10,0	10,0	10,0	10,0

REF							
	837L-	010	012	014	016	018	M-FG
■	837L-			014	016		SC-FG
■	837L-	010	012	014	016	018	C-FG
■	837L-		012				F-FG



**838  
(137)**

Henger, gömbölyű



Átmérő mérete 1/10 mm	008	009	010	012	014
Hossz mm-ben	3,0	3,0	4,0	4,0	4,0

REF							
	838-	008	009	010	012	014	M-FG
■	838-				012	014	SC-FG
■	838-			010	012	014	C-FG
■	838-			010			F-FG

M	gyűrű nélkül	közepes	107-126 μm	ISO 524	■	C	zöld gyűrű	druva	151 μm	ISO 534	■	SF	sárga gyűrű	különösen finom	20 μm	ISO 504	
■	SC	fekete gyűrű	különösen durva	181 μm	ISO 544	■	F	piros gyűrű	finom	40 μm	ISO 514	□	UF	fehér gyűrű	ultrafinom	15 μm	ISO 494



**839**  
**(150)**

Homlokcsiszoló

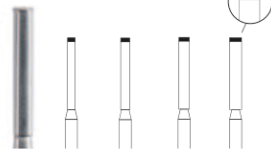

Átmérő mérete 1/10 mm	010	012	014	016	
Hossz mm-ben	0,1	0,1	0,1	0,1	

REF

839-	010	012	014	016	M-FG
839-	010	012	014		F-FG



**840**  
**(722)**

Homlokcsiszoló

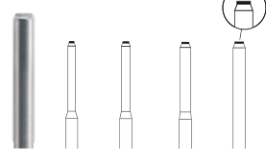

Átmérő mérete 1/10 mm	010	012	014	016	
Hossz mm-ben	0,1	0,1	0,1	0,1	

REF

840-	010	012	014	016	M-FG
------	-----	-----	-----	-----	------



**842**  
**(113)**

Henger

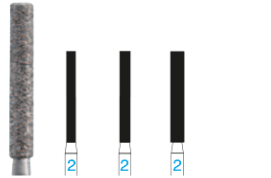

Átmérő mérete 1/10 mm	012	014	018	
Hossz mm-ben	12,0	12,0	12,0	

REF

842-	012	014		M-FG
842-	012	014		SC-FG
842-	012	014	018	C-FG

Kézzónás gyémánt  
csiszolók

**844**  
**(199)**  
Kúp, gömbölyű

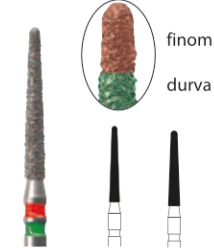

Átmérő mérete 1/10 mm	014	016	
Hossz mm-ben	10,0	10,0	

REF

844-	014	016	F/C-FG
------	-----	-----	--------

opt. 70.000 - 140.000 rpm



**845KR**  
**(544)**

Kúp,  
gömbölyű munkaél



Átmérő mérete 1/10 mm	016	018	025	
Hossz mm-ben	4,0	4,0	4,0	

REF

845KR-	016	018	025	M-FG
845KR-	016			SC-FG
845KR-	016	018	025	C-FG
845KR-	016	018	025	F-FG
845KR-			025	SF-FG



**845**  
**(170)**

Kúp



Átmérő mérete 1/10 mm	009	010	012	014	016
Hossz mm-ben	3,0	4,0	4,0	4,0	4,0

REF

845-	010				M-FGM	
845-	009	010	012	014	016	M-FG
845-			012	014	016	C-FG
845-		010	012			M-RA



**846**  
**(171)**

Kúp



Átmérő mérete 1/10 mm	012	014	016	025	
Hossz mm-ben	6,0	6,0	6,0	7,0	

REF

846-	012	014	016		M-FG
846-	012	014	016	025	C-FG
846-	012		016	025	F-FG



**846KR**  
**(545)**

gömbölyű munkaél

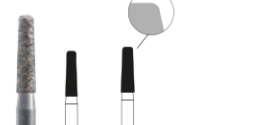

Átmérő mérete 1/10 mm	016	018	
Hossz mm-ben	6,0	5,5	

REF

846KR-	016	018	M-FG
846KR-	016		SC-FG
846KR-	016		C-FG
846KR-	016	018	F-FG



**847**  
**(172)**

Kúp, lapos

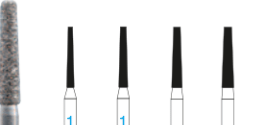

Átmérő mérete 1/10 mm	010	012	014	016	018	023
Hossz mm-ben	8,0	8,0	8,0	8,0	8,0	8,0

REF

847-				016		SC-FGM	
847-				016		C-FGM	
847-	010	012	014	016	018	023	M-FG
847-		012	014	016	018	023	SC-FG
847-	010	012	014	016	018	023	C-FG
847-	010	012	014	016			F-FG
847-	010						SF-FG



**847KR (546)**

Kúp, gömbölyű munkaél

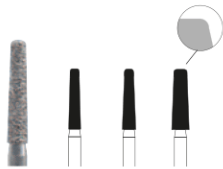

Átmérő mérete 1/10 mm	016	018	023
Hossz mm-ben	8,0	8,0	8,0

REF

■	847KR-	016				SC-FGM
	847KR-	016	018	023		M-FG
■	847KR-	016	018			SC-FG
■	847KR-	016	018	023		C-FG
■	847KR-	016	018	023		F-FG



**848 (173)**

Kúp, lapos

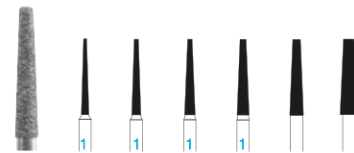

Átmérő mérete 1/10 mm	010	012	014	016	018	023
Hossz mm-ben	100	100	100	100	100	100

REF

	848-			014				M-FGM
	848-	010	012	014	016	018	023	M-FG
■	848-				016	018	023	SC-FG
■	848-	010	012	014	016	018	023	C-FG
■	848-	010	012	014	016	018		F-FG
■	848-	010	012	014	016			SF-FG



**848L (174)**

Kúp, hosszú



Átmérő mérete 1/10 mm	012	014	016	018	021
Hossz mm-ben	11,5	11,5	11,5	11,5	11,5

REF

■	848L-	012	014	016	018	021	M-FG
■	848L-		014	016	018		SC-FG
■	848L-		014	016	018		C-FG
■	848L-		014				F-FG



**849 (196)**

Kúp, gömbölyű



Átmérő mérete 1/10 mm	009	010	012	014	016	025
Hossz mm-ben	4,0	4,0	4,0	4,0	4,0	4,0

REF

■	849-	009	010	012			025	M-FG
■	849-						025	SC-FG
■	849-	009	010	012	014	016	025	C-FG
■	849-	009	010	012				F-FG
■	849-		010					SF-FG



**850 (199)**

Kúp, gömbölyű



Átmérő mérete 1/10 mm	010	012	014	016	018	023	031
Hossz mm-ben	100	100	100	100	100	100	100

REF

■	850-			014				C-FGM	
■	850-	010	012	014	016	018	023	031	M-FG
■	850-			014	016	018	023		SC-FG
■	850-	010	012	014	016	018	023	031	C-FG
■	850-	010	012	014	016	018	023		F-FG
■	850-	010	012	014	016	018			SF-FG
■	850-		012						M-RA



**850L (200)**

Kúp, hosszú, gömbölyű



Átmérő mérete 1/10 mm	012	014	016	018
Hossz mm-ben	11,5	11,5	11,5	11,5

REF

■	850L-	012	014	016	018	M-FG
■	850L-		014	016	018	SC-FG
■	850L-	012	014	016	018	C-FG
■	850L-	012	014	016		F-FG
■	850L-	012	014			SF-FG



**850KR (553)**

Kúp, gömbölyű munkaél

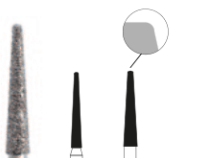

Átmérő mérete 1/10 mm	014	018
Hossz mm-ben	100	100

REF

■	850KR-		018	M-FGM
■	850KR-	014	018	M-FG
■	850KR-	014	018	SC-FG
■	850KR-	014	018	C-FG



**851 (219)**

Kúp, inykimélő biztonsági csúsz



Átmérő mérete 1/10 mm	010	012	016
Hossz mm-ben	8,0	8,0	8,0

REF

■	851-	010	012	016	M-FG
■	851-		012	016	C-FG
■	851-	010	012		F-FG



**852 (164)**

Kúp, csúcsos

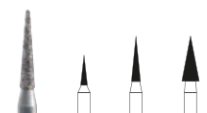

Átmérő mérete 1/10 mm	010	012	023
Hossz mm-ben	4,0	6,0	6,0

REF

■	852-	010	012	023	M-FG
■	852-			023	SC-FG
■	852-		012	023	C-FG
■	852-	010	012		F-FG
■	852-	010	012		SF-FG
□	852-		012		UF-FG

■	M	gyűrű nélkül	közepes	107-126 μm	ISO 524	■	C	zöld gyűrű	druva	151 μm	ISO 534	■	SF	sárga gyűrű	különösen finom	20 μm	ISO 504
■	SC	fekete gyűrű	különösen durva	181 μm	ISO 544	■	F	piros gyűrű	finom	40 μm	ISO 514	□	UF	fehér gyűrű	ultrafinom	15 μm	ISO 494



**855  
(197)**

Kúp, gömbölyű

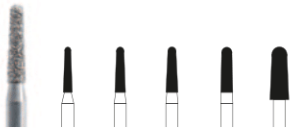

Átmérő mérete 1/10 mm	012	014	016	018	025	
Hossz mm-ben	6,0	6,0	6,0	6,0	6,0	

	REF					
■	855-	012				C-FGM
	855-	012	014		025	M-FG
■	855-	012	014	016	018	025 SC-FG
■	855-	012	014		025	C-FG
■	855-	012	014			F-FG
■	855-		014			SF-FG



**856  
(198)**

Kúp, gömbölyű

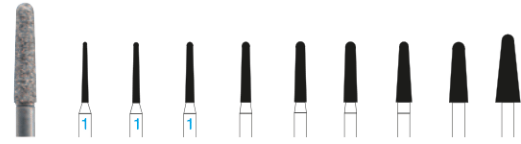

Átmérő mérete 1/10 mm	009	010	012	014	016	018	021	025	033
Hossz mm-ben	8,0	8,0	8,0	8,0	8,0	8,0	8,0	8,0	9,0

	REF								
■	856-		012						M-FGM
■	856-		012	014	016	018	021	025	SC-FGM
■	856-		012	014	016	018			C-FGM
■	856-	009	010	012	014	016	018	021	025 M-FG
■	856-		012	014	016	018	018	021	025 033 SC-FG
■	856-		012	014	016	018	021	025	C-FG
■	856-	009	010	012	014	016	018	021	025 F-FG
■	856-	009	010	012	014	016		021	SF-FG



**856L  
(199)**

Kúp, gömbölyű,  
hosszú

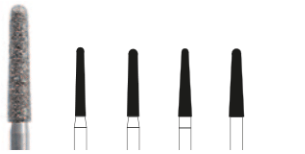

Átmérő mérete 1/10 mm	014	016	018	020	
Hossz mm-ben	9,0	9,0	9,0	9,0	

	REF					
■	856L-	014	016	018	020	M-FG
■	856L-	014	016	018	020	SC-FG
■	856L-	014	016	018	020	C-FG
■	856L-	014	016	018	020	F-FG



**857  
(220)**

Kúp, gömbölyű, íny-  
kímélő biztonsági csúcs

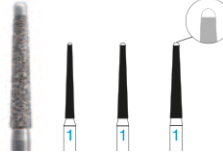

Átmérő mérete 1/10 mm	012	014	016	
Hossz mm-ben	10,0	10,0	10,0	

	REF				
■	857-	012	014	016	M-FG
■	857-		014		SC-FG
■	857-	012	014	016	C-FG
■	857-	012	014		F-FG
■	857-	012			SF-FG



**858  
(165)**

Kúp, csúcsos



Átmérő mérete 1/10 mm	010	012	014	016	018
Hossz mm-ben	8,0	8,0	8,0	8,0	8,0

	REF					
■	858-		014			M-FGM
■	858-		014			C-FGM
■	858-		014			SF-FGM
■	858-	010	012	014	016	018 M-FG
■	858-		014	016	018	SC-FG
■	858-	010	012	014	016	018 C-FG
■	858-	010	012	014	016	018 F-FG
■	858-	010	012	014	016	SF-FG
■	858-		014			UF-FG



**859L  
(167)**

Kúp, csúcsos  
hosszú

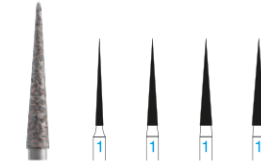

Átmérő mérete 1/10 mm	010	014	016	018
Hossz mm-ben	11,5	11,5	11,5	11,5

	REF				
■	859L-	010	014	016	018 M-FG
■	859L-		016	018	SC-FG
■	859L-		014	016	018 C-FG
■	859L-	010	014	016	F-FG
■	859L-	010	014	016	018 SF-FG
■	859L-	010			UF-FG



**859CL  
(193)**

Kúp, hegyes,  
hosszú



Átmérő mérete 1/10 mm	010
Hossz mm-ben	11,5

	REF	
■	859CL-	010 M-FG



**859  
(166)**

Kúp, csúcsos

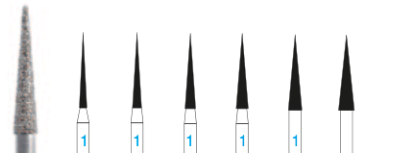

Átmérő mérete 1/10 mm	010	012	014	016	018	021
Hossz mm-ben	10,0	10,0	10,0	10,0	10,0	10,0

	REF					
■	859-		016			M-FGM
■	859-	010	012	014	016	018 021 M-FG
■	859-			018		SC-FG
■	859-	010	012	014	016	018 021 C-FG
■	859-	010	012	014	016	018 F-FG
■	859-	010	012	014	016	018 SF-FG
■	859-	010	012	014	016	UF-FG
■	859-		012	016		M-RA



**860  
(247)**

Láng



Átmérő mérete 1/10 mm	010	012	014	016
Hossz mm-ben	4,0	5,0	5,0	5,0

	REF				
■	860-		012		C-FGM
■	860-	010	012	014	016 M-FG
■	860-		014		SC-FG
■	860-	010	012	014	016 C-FG
■	860-	010	012	014	016 F-FG
■	860-	010	012	014	F-FG
■	860-		012		M-RA

# gyémántcsiszolók FGL/FG/FGM/RA



**861 (248)**  
Láng



Átmérő mérete 1/10 mm	012	014
Hossz mm-ben	6,0	6,0

REF			
861-	012	014	M-FG
861-	012	014	C-FG
861-	012	014	F-FG
861-	012	014	SF-FG



**862 (249)**  
Láng

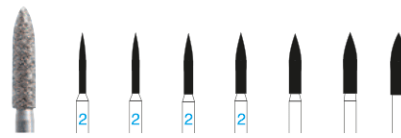

Átmérő mérete 1/10 mm	009	010	012	014	016	018	021
Hossz mm-ben	8,0	8,0	8,0	8,0	8,0	8,0	8,0

REF							
862-				016			M-FGM
862-		010	012	014			C-FGM
862-	009	010	012	014	016	018	021
862-			012	014	016	018	SC-FG
862-		010	012	014	016	018	C-FG
862-	009	010	012	014	016		F-FG
862-	009	010	012	014	016		SF-FG
862-		010		014			UF-FG
862-			012				M-RA



**863SE (256)**  
Láng, inykímélő biztonsági csúcs



Átmérő mérete 1/10 mm	012
Hossz mm-ben	10,0

REF		
863SE-	012	M-FG



**863 (250)**  
Láng

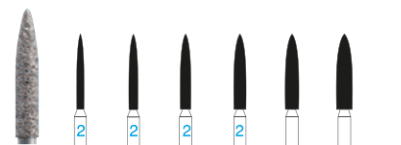

Átmérő mérete 1/10 mm	010	012	014	016	018	021
Hossz mm-ben	100	100	100	100	100	100

REF						
863-		012				C-FGM
863-	010	012	014	016	018	M-FG
863-	012	014	016	018	021	SC-FG
863-	012	014	016	018	021	C-FG
863-	010	012	014	016	018	F-FG
863-	010	012	014	016		SF-FG
863-		012				UF-FG



**863L (252)**  
Láng, hosszú



Átmérő mérete 1/10 mm	016
Hossz mm-ben	100

REF		
863L-	016	M-FG
863L-	016	C-FG



**864 (251)**  
Láng

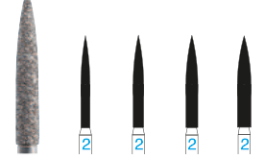

Átmérő mérete 1/10 mm	012	014	016	018
Hossz mm-ben	12,0	12,0	12,0	12,0

REF					
864-	012	014	016	018	M-FG
864-			016	018	SC-FG
864-		014	016	018	C-FG
864-	012	014	016		F-FG
864-	012	014	016		SF-FG



**869 (222)**  
Kúp, gömbölyű



Átmérő mérete 1/10 mm	014	016
Hossz mm-ben	6,0	6,0

REF		
869-	014	016
869-	014	016



**874 (534)**  
Torpedó



Átmérő mérete 1/10 mm	009
Hossz mm-ben	2,0

REF	
874-	009
874-	009



**875 (535)**  
Torpedó



Átmérő mérete 1/10 mm	009	010
Hossz mm-ben	3,0	4,0

REF		
875-	009	010
875-	009	010



**876 (287)**  
Torpedó



Átmérő mérete 1/10 mm	009
Hossz mm-ben	5,0

REF		
876-	009	M-FG
876-	009	F-FG



**876K (296)**  
Torpedó, kúpos



Átmérő mérete 1/10 mm	012
Hossz mm-ben	5,0

REF		
876K-	012	M-FG
876K-	012	C-FG



**877 (288)**  
Torpedó

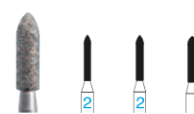

Átmérő mérete 1/10 mm	009	010	012
Hossz mm-ben	6,0	6,0	6,0

REF			
877-	009	010	012
877-			012
877-		010	012



**877K (297)**  
Torpedó, kúpos



Átmérő mérete 1/10 mm	012	014	016	018
Hossz mm-ben	6,0	6,0	6,0	6,0

REF				
877K-	012	014	016	M-FG
877K-		014	016	018
877K-	012	014	016	018
877K-		014	016	F-FG

M	gyűrű nélkül	közepes	107-126 μm	ISO 524	C	zöld gyűrű	druva	151 μm	ISO 534	SF	sárga gyűrű	különösen finom	20 μm	ISO 504
SC	fekete gyűrű	különösen durva	181 μm	ISO 544	F	piros gyűrű	finom	40 μm	ISO 514	UF	fehér gyűrű	ultrafinom	15 μm	ISO 494



## 878 (289)

Torpedó



Átmérő mérete 1/10 mm	008	009	010	012	014	016	018
Hossz mm-ben	8,0	8,0	8,0	8,0	8,0	8,0	8,0

REF

■	878-			012	014			C-FGM	
■	878-				014			F-FGM	
■	878-	008	009	010	012	014	016	018	M-FG
■	878-			012	014	016	018		SC-FG
■	878-			010	012	014	016	018	C-FG
■	878-	008	009	010	012	014	016		F-FG
■	878-			010	012	014			SF-FG



## 878K (298)

Torpedó, kúpos

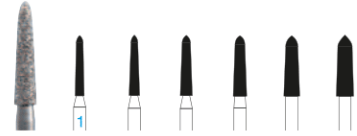

Átmérő mérete 1/10 mm	012	014	016	018	021	023
Hossz mm-ben	8,0	8,0	8,0	8,0	8,0	8,0

REF

■	878K-	012	014	016	018	021		M-FG
■	878K-	012	014	016	018	021	023	SC-FG
■	878K-	012	014	016	018	021	023	C-FG
■	878K-	012	014	016	018	021		F-FG



## 879 (290)

Torpedó

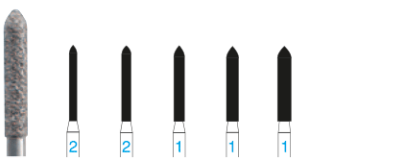

Átmérő mérete 1/10 mm	010	012	014	016	018
Hossz mm-ben	100	100	100	100	100

REF

■	879-	010	012	014	016	018		M-FG
■	879-		012	014	016	018		SC-FG
■	879-	010	012	014	016	018		C-FG
■	879-	010	012	014	016	018		F-FG
■	879-		012	014	016			SF-FG



## 879K (299)

Torpedó, kúpos

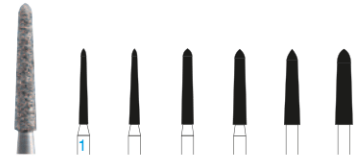

Átmérő mérete 1/10 mm	012	014	016	018	021	023
Hossz mm-ben	100	100	100	100	100	100

REF

■	879K-			016				M-FGM
■	879K-	012	014	016	018	021		M-FG
■	879K-	012	014	016	018	021	023	SC-FG
■	879K-	012	014	016	018	021	023	C-FG
■	879K-	012	014	016	018			F-FG
■	879K-	012	014	016				SF-FG



## 879L (291)

Torpedó hosszú



Átmérő mérete 1/10 mm	012	014
Hossz mm-ben	120	120

REF

■	879L-	012	014			M-FG
■	879L-	012	014			SC-FG
■	879L-	012	014			C-FG
■	879L-	012	014			F-FG



## 880 (140)

Henger, gömblyű

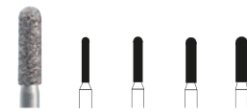

Átmérő mérete 1/10 mm	010	012	014	016
Hossz mm-ben	6,0	6,0	6,0	6,0

REF

■	880-	010	012	014	016	M-FG
■	880-			014		SC-FG
■	880-		012	014	016	C-FG
■	880-		012	014		F-FG



## 881KS (146)

Henger KS

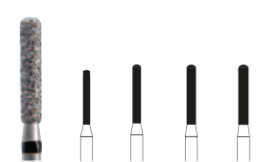

Átmérő mérete 1/10 mm	012	014	015	016
Hossz mm-ben	7,0	8,0	8,0	8,0

REF

■	881KS-	012	014	015	016	SC-FG
---	--------	-----	-----	-----	-----	-------



## 881 (141)

Henger, gömblyű

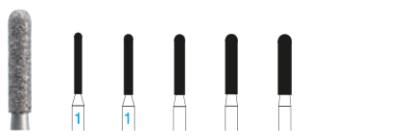

Átmérő mérete 1/10 mm	010	012	014	016	018
Hossz mm-ben	8,0	8,0	8,0	8,0	8,0

REF

■	881-	010	012	014	016	018	M-FG
■	881-			014	016	018	SC-FG
■	881-	010	012	014	016	018	C-FG
■	881-	010	012	014	016	018	F-FG
■	881-		012	014			SF-FG



## 882 (142)

Henger, gömblyű



Átmérő mérete 1/10 mm	010	012	014
Hossz mm-ben	100	100	100

REF

■	882-	010	012	014	M-FG
■	882-			014	SC-FG
■	882-	010	012	014	C-FG
■	882-	010	012	014	F-FG
■	882-	010	012		SF-FG



## 883 (539)

Láng



Átmérő mérete 1/10 mm	010
Hossz mm-ben	3,0

REF

■	883-	010	M-FG
■	883-	010	C-FG
■	883-	010	F-FG



**884 (129)**  
Henger, hegyes



Átmérő mérete 1/10 mm	010	012	
Hossz mm-ben	6,0	6,0	

REF				
884-	010			M-FG
884-		012		C-FG
884-		012		F-FG



**885 (130)**  
Henger, hegyes

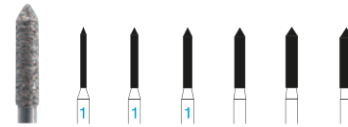

Átmérő mérete 1/10 mm	008	010	012	014	016	018
Hossz mm-ben	8,0	8,0	8,0	8,0	8,0	8,0

REF						
885-			012			C-FGM
885-	008	010	012	014		M-FG
885-			012	014		018 SC-FG
885-			012	014	016	C-FG
885-		010	012	014		F-FG



**886 (131)**  
Henger, hegyes

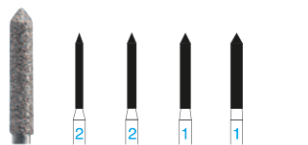

Átmérő mérete 1/10 mm	010	012	014	016
Hossz mm-ben	10,0	10,0	10,0	10,0

REF					
886-	010	012	014	016	M-FG
886-		012	014	016	SC-FG
886-		012	014	016	C-FG
886-	010	012	014	016	F-FG



**888 (496)**  
Láng



Átmérő mérete 1/10 mm	012
Hossz mm-ben	8,0

REF		
888-	012	M-FG
888-	012	C-FG
888-	012	F-FG
888-	012	SF-FG



**889 (540)**  
Láng



Átmérő mérete 1/10 mm	009	010
Hossz mm-ben	3,5	4,0

REF		
889-	009	010
889-		010
889-	009	010
889-	009	010
889-	009	010



**898 (213)**  
Láng



Átmérő mérete 1/10 mm	016
Hossz mm-ben	10,5

REF		
898-	016	M-FG
898-	016	C-FG
898-	016	F-FG



**899 (033)**  
Palatinális

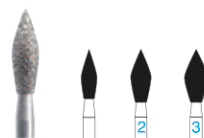

Átmérő mérete 1/10 mm	021	027	031
Hossz mm-ben	6,5	7,0	7,0

REF			
899-	021	027	031
899-	021	027	031
899-	021	027	031
899-	021	027	031



**909 (068)**  
Abrons

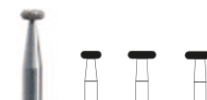

Átmérő mérete 1/10 mm	027	037	040
Hossz mm-ben	1,0	1,0	1,0

REF			
909-	027	037	040
909-			040
909-		037	040



**970 (463)**  
Rágófelszíni vágó, kontúrozó



Átmérő mérete 1/10 mm	023
Hossz mm-ben	1,6

REF		
970-	023	M-FGM
970-	023	F-FGM



**980 (463)**  
Rágófelszíni vágó, kontúrozó

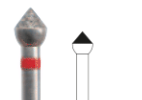

Átmérő mérete 1/10 mm	027
Hossz mm-ben	1,6

REF		
980-	027	M-FGM
980-	027	F-FGM



**985 (463)**  
Rágófelszíni vágó, kontúrozó



Átmérő mérete 1/10 mm	031
Hossz mm-ben	1,7

REF		
985-	031	F-FGM



**972 (270)**  
Lövédékgömbölyű



Átmérő mérete 1/10 mm	020
Hossz mm-ben	4,0

REF		
972-	020	F-FGL
972-	020	SF-FGL

M	gyűrű nélkül	közepes	107-126 μm	ISO 524	C	zöld gyűrű	druva	151 μm	ISO 534	SF	sárga gyűrű	különösen finom	20 μm	ISO 504
SC	fekete gyűrű	különösen durva	181 μm	ISO 544	F	piros gyűrű	finom	40 μm	ISO 514	UF	fehér gyűrű	ultrafinom	15 μm	ISO 494

## Gyémántcsiszolók vezetőcsúccsal VKP Teljes kerámia preparáció

**998 (508)**

Gömbölyű kúp, csappal

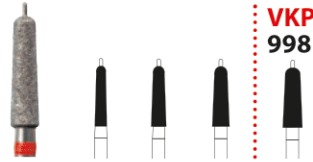

Átmérő mérete 1/10 mm	016	021	023	026
Hossz mm-ben	9,0	9,0	9,0	9,0
REF				
998-				026 M-FG
■ 998-	016	021	023	SC-FG
■ 998-	016	021	023	026 F-FG
Vágási mélység T mm	0,4	0,6	0,7	0,8

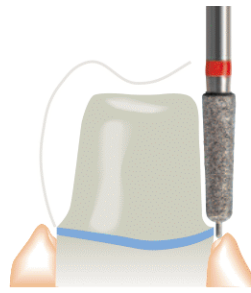

998-021SC-FG

- ⌚ max. F minden méret (átmérő) = 40.000 min<sup>-1</sup>
- ⌚ max. 016SC = 450.000 min<sup>-1</sup>
- ⌚ max. 021SC, 023SC = 300.000 min<sup>-1</sup>
- ⌚ max. 026M = 160.000 min<sup>-1</sup>

### LAZYBUR

**986 (464)**

Rágófelszíni vágó, kontúrozó

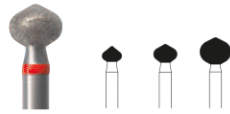

Átmérő mérete 1/10 mm	026	031	041
Hossz mm-ben	2,0	2,4	3,5
REF			
986-			041 M-FG
■ 986-	026	031	041 F-FG
■ 986-	026	031	041 SF-FG

- ⌚ opt. ■ SF 8.000–15.000 rpm, ■ F 10.000–20.000 rpm
- 041M 15.000–60.000 rpm



986-041SF-FG



REF SET-1934

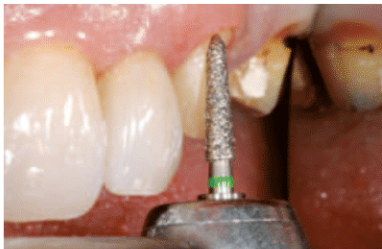

878KSE-022C-FG



878KSE-022F-FG



## Easy Chamfer

Optimális chamfer vállas preparáció - gyors - egyszerű - tökéletes.



**878KSE**  
Torpedó, kúpos, curettage



Átmérő mérete 1/10 mm	019	022
Hossz mm-ben	8,0	8,0
REF		
■ 878KSE-	019	022 C-FG
■ 878KSE-	019	022 F-FG

- ◇ opt. -019C 55.000 - 160.000 rpm
- ◇ opt. -022C 40.000 - 120.000 rpm
- ◇ opt. -...F 10.000 - 20.000 rpm



**879KSE**  
Torpedó, kúpos, curettage



Átmérő mérete 1/10 mm	021	024
Hossz mm-ben	10,0	10,0
REF		
■ 879KSE-	021	024 C-FG
■ 879KSE-	021	024 F-FG

- ◇ opt. -021C/-024C 40.000 - 120.000 rpm
- ◇ opt. -...F 10.000 - 20.000 rpm



**879LSE**  
Torpedó hosszú



Átmérő mérete 1/10 mm	014
Hossz mm-ben	12,0
REF	
■ 879LSE-	014 C-FG
■ 879LSE-	014 F-FG

- ◇ opt. 40.000 - 85.000 rpm
- ◇ opt. 10.000 - 20.000 rpm

M gyűrű nélkül közepes 107-126 µm ISO 524	■ C zöld gyűrű druva 151 µm ISO 534	■ SF sárga gyűrű különösen finom 20 µm ISO 504
■ SC fekete gyűrű különösen durva 181 µm ISO 544	■ F piros gyűrű finom 40 µm ISO 514	□ UF fehér gyűrű ultrafinom 15 µm ISO 494



**878SE**  
(255)  
Torpedó



Átmérő mérete 1/10 mm	012	015	
Hossz mm-ben	8,0	8,0	
	REF		
<span style="color: green;">■</span>	878SE-	012	015 C-FG
<span style="color: red;">■</span>	878SE-	012	015 F-FG

- ◊ ◌ opt. 012C 40.000 - 85.000 rpm
- ◊ ◌ opt. 015C 70.000 - 140.000 rpm
- ◊ ◌ opt. ...F 10.000 - 20.000 rpm

**879SE**  
(256)  
Torpedó

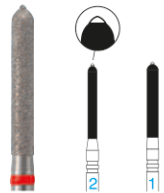

Átmérő mérete 1/10 mm	012	015	
Hossz mm-ben	10,0	10,0	
	REF		
<span style="color: green;">■</span>	879SE-	012	015 C-FG
<span style="color: red;">■</span>	879SE-	012	015 F-FG

- ◊ ◌ opt. 012C 40.000 - 85.000 rpm
- ◊ ◌ opt. 015C 70.000 - 140.000 rpm
- ◊ ◌ opt. ...F 10.000 - 20.000 rpm

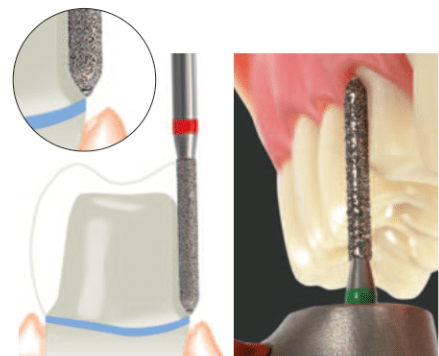

879SE-012F-FG

879SE-012C-FG

## InPrep

Kavitás-előkészítés 30 másodperc alatt

**836KRS**  
Henger, gömbölyű munkaél biztonsági terület



Átmérő mérete 1/10 mm	014	
Hossz mm-ben	6,0	
	REF	
<span style="color: green;">■</span>	836KRS-	014 C-FG
<span style="color: red;">■</span>	836KRS-	014 F-FG

- C ◌ opt. 55.000-160.000 rpm
- F ◌ opt. 10.000-20.000 rpm

**845KRS**  
Kúp, gömbölyű munkaél biztonsági terület



Átmérő mérete 1/10 mm	017	
Hossz mm-ben	4,0	
	REF	
<span style="color: green;">■</span>	845KRS-	017 C-FG
<span style="color: red;">■</span>	845KRS-	017 F-FG

- C ◌ opt. 55.000-160.000 rpm
- F ◌ opt. 10.000-20.000 rpm

**846KRS**  
Henger, gömbölyű munkaél biztonsági terület

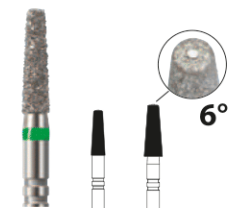

Átmérő mérete 1/10 mm	019	025
Hossz mm-ben	6,0	7,0
	REF	
<span style="color: green;">■</span>	846KRS-	019 025 C-FG
<span style="color: red;">■</span>	846KRS-	019 025 F-FG

- ISO 019 ◌ opt. C = 55.000-160.000 rpm
- ◌ opt. F = 10.000-20.000 rpm
- ISO 025 ◌ opt. C = 35.000-110.000 rpm
- ◌ opt. F = 10.000-20.000 rpm

## Z-Cut csiszolók

**K369**  
(263)  
Csepp



Átmérő mérete 1/10 mm	025	
Hossz mm-ben	5,5	
	REF	
<span style="color: red;">■</span>	K369-	025 F-FG
<span style="color: yellow;">■</span>	K369-	025 SF-FG
<span style="color: white;">□</span>	K369-	025 UF-FG

- ◌ opt. 200.000 rpm

**K379L**  
(277)  
Football



Átmérő mérete 1/10 mm	012	
Hossz mm-ben	3,0	
	REF	
<span style="color: red;">■</span>	K379L-	012 F-FGL

- ◌ opt. 200.000 rpm

**K801L**  
(697)  
Gömbölyű, hosszú



Átmérő mérete 1/10 mm	014	
Hossz mm-ben		
	REF	
<span style="color: red;">■</span>	K801L-	014 F-FG
<span style="color: yellow;">■</span>	K801L-	014 SF-FG
<span style="color: white;">□</span>	K801L-	014 UF-FG

- ◌ opt. 200.000 rpm

**K847KR**  
(546)  
Kúp, gömbölyű munkaél



Átmérő mérete 1/10 mm	016	025
Hossz mm-ben	8,0	8,0
	REF	
<span style="color: red;">■</span>	K847KR-	016 025 F-FG
<span style="color: yellow;">■</span>	K847KR-	016 025 SF-FG

- ◌ opt. 200.000 rpm

**K859L**  
(167)  
Kúp, csúcsos hosszú

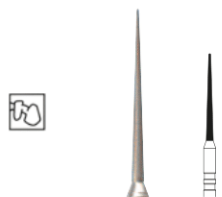

Átmérő mérete 1/10 mm	010	
Hossz mm-ben	11,5	
	REF	
<span style="color: red;">■</span>	K859L-	010 F-FG
<span style="color: yellow;">■</span>	K859L-	010 SF-FG
<span style="color: white;">□</span>	K859L-	010 UF-FG

- ◌ opt. 200.000 rpm

**K879**  
(290)  
Torpedó



Átmérő mérete 1/10 mm	014	
Hossz mm-ben	10,0	
	REF	
<span style="color: blue;">■</span>	K879-	014 M-FG
<span style="color: red;">■</span>	K879-	014 F-FG
<span style="color: yellow;">■</span>	K879-	014 SF-FG
<span style="color: white;">□</span>	K879-	014 UF-FG

- ◌ opt. 200.000 rpm

## Z-Cut csiszolók

Elsősorban égetett cirkonkerámia koronák trepanálásához

### ZirPan K802L (494)

Gömbölyű, hosszabítással

Átmérő mérete 1/10 mm	021
Hossz mm-ben	10,0

REF	K802L-	021	M-FG
-----	--------	-----	------

opt. 200.000 rpm

Elsősorban égetett cirkonkerámia koronák trepanálásához

### K856 (198)

Kúp, gömbölyű

Átmérő mérete 1/10 mm	016
Hossz mm-ben	8,0

REF	K856-	016	M-FG
	K856-	016	F-FG
	K856-	016	SF-FG
	K856-	016	UF-FG

opt. 200.000 rpm

Elsősorban égetett cirkonkerámia koronák trepanálásához

### K881 (141)

Henger, gömbölyű

Átmérő mérete 1/10 mm	012	016
Hossz mm-ben	8,0	8,0

REF	K881-	012	016	M-FG
	K881-	012	016	F-FG
	K881-	016	016	SF-FG
	K881-	016	016	UF-FG

opt. 200.000 rpm

## FG TURBO - gyémántcsiszolók



### 379 (277)

Tojásdad

Átmérő mérete 1/10 mm	023
Hossz mm-ben	4,5

REF	379-	023	TSC-FG
-----	------	-----	--------



### 811 (038)

Kettős kúp

Átmérő mérete 1/10 mm	033
Hossz mm-ben	4,2

REF	811-	033	TC-FG
	811-	033	TSC-FG



### 822 (237)

Körte

Átmérő mérete 1/10 mm	012
Hossz mm-ben	3,0

REF	822-	012	TSC-FG
-----	------	-----	--------



### 836 (110)

Henger

Átmérő mérete 1/10 mm	012
Hossz mm-ben	6,0

REF	836-	012	TSC-FG
-----	------	-----	--------



### 830L (239)

Körte, hosszú

Átmérő mérete 1/10 mm	012	014	016	018
Hossz mm-ben	4,0	5,0	5,0	5,0

REF	830L-	012	014	TC-FG		
	830L-	012	014	016	018	TSC-FG



### 837 (111)

Henger

Átmérő mérete 1/10 mm	012	014	016
Hossz mm-ben	8,0	8,0	8,0

REF	837-	012	014	016	TSC-FG
-----	------	-----	-----	-----	--------



### 837KR (158)

Henger, gömbölyű munkaél

Átmérő mérete 1/10 mm	014	016
Hossz mm-ben	8,0	8,0

REF	837KR-	014	016	TSC-FG
-----	--------	-----	-----	--------



### 846KR (545)

Kúp, gömbölyű munkaél

Átmérő mérete 1/10 mm	016
Hossz mm-ben	6,0

REF	846KR-	016	TSC-FG
-----	--------	-----	--------



### 847 (172)

Kúp

Átmérő mérete 1/10 mm	014	016
Hossz mm-ben	8,0	8,0

REF	847-	014	016	TSC-FG
-----	------	-----	-----	--------



### 847KR (546)

Kúp, gömbölyű munkaél

Átmérő mérete 1/10 mm	016
Hossz mm-ben	8,0

REF	847KR-	016	TSC-FG
-----	--------	-----	--------



### 848 (173)

Kúp, lapos

Átmérő mérete 1/10 mm	016	018
Hossz mm-ben	100	100

REF	848-	016	TC-FG	
	848-	016	018	TSC-FG

**850 (199)**  
Kúp, gömbölyű

Átmérő mérete 1/10 mm	012	014	016	018	
Hossz mm-ben	100	100	100	100	

REF

■	850-	012	014	016	018	TC-FG
■	850-		014	016	018	TSC-FG

**855 (197)**  
Kúp, gömbölyű

Átmérő mérete 1/10 mm	014	025	
Hossz mm-ben	6,0	7,0	

REF

■	855-	014	025	TSC-FG
---	------	-----	-----	--------

**859 (166)**  
Kúp, csúszos

Átmérő mérete 1/10 mm	018	
Hossz mm-ben	100	

REF

■	859-	018	TSC-FG
---	------	-----	--------

**856 (198)**  
Kúp, gömbölyű

Átmérő mérete 1/10 mm	012	014	016	018	025	
Hossz mm-ben	8,0	8,0	8,0	8,0	8,0	

REF

■	856-		014	016	018	TSC-FGM
■	856-			016		TC-FG
■	856-	012	014	016	018	025 TSC-FG

**862 (249)**  
Láng

Átmérő mérete 1/10 mm	012	014	
Hossz mm-ben	8,0	8,0	

REF

■	862-	012	014	TSC-FG
---	------	-----	-----	--------

**863 (250)**  
Láng

Átmérő mérete 1/10 mm	012	014	016	
Hossz mm-ben	100	100	100	

REF

■	863-	012	014	016	TSC-FG
---	------	-----	-----	-----	--------

**878 (289)**  
Torpedó

Átmérő mérete 1/10 mm	012	014	
Hossz mm-ben	8,0	8,0	

REF

■	878-	012	014	TSC-FG
---	------	-----	-----	--------

**878K (298)**  
Torpedó, kúpos

Átmérő mérete 1/10 mm	014	016	
Hossz mm-ben	8,0	8,0	

REF

■	878K-	014	016	TSC-FG
---	-------	-----	-----	--------

**879L (291)**  
Torpedó, hosszú

Átmérő mérete 1/10 mm	012	014	
Hossz mm-ben	120	120	

REF

■	879L-	012	014	TSC-FG
---	-------	-----	-----	--------

**879 (290)**  
Torpedó

Átmérő mérete 1/10 mm	012	014	016	
Hossz mm-ben	100	100	100	

REF

■	879-		014	016	TC-FG
■	879-	012	014	016	TSC-FG

**879K (299)**  
Torpedó, kúpos

Átmérő mérete 1/10 mm	014	016	018	
Hossz mm-ben	100	100	100	

REF

■	879K-	014	016	018	TC-FG
■	879K-	014	016	018	TSC-FG

**881 (141)**  
Henger, gömbölyű

Átmérő mérete 1/10 mm	012	014	
Hossz mm-ben	8,0	8,0	

REF

■	881-	012	014	TC-FG
---	------	-----	-----	-------

**882 (142)**  
Henger, gömbölyű

Átmérő mérete 1/10 mm	012	014	
Hossz mm-ben	100	100	

REF

■	882-	012	014	TC-FG
---	------	-----	-----	-------

**885 (130)**  
Henger, hegyes

Átmérő mérete 1/10 mm	012	
Hossz mm-ben	8,0	

REF

■	885-	012	TSC-FG
---	------	-----	--------

**886 (131)**  
Henger, hegyes

Átmérő mérete 1/10 mm	012	014	
Hossz mm-ben	100	100	

REF

■	886-	012	014	TSC-FG
---	------	-----	-----	--------

## Szeparáló csík

### Szeparáló csík fűrészfogazat nélkül

**FS2-M, FS2-F, FS2-SF** gyémántmentes tartomány  
← 16 mm →

Szinkódolás	FS2-M	FS2-F	FS2-SF
Vastagság mm	0,13	0,10	0,08
Szélesség (mm)	2,50	2,50	2,50
Hossz mm-ben	147,0	147,0	147,0



REF

<b>FS2-M</b>	
<b>FS2-F</b>	
<b>FS2-SF</b>	

**FS3-M, FS3-F, FS3-SF** gyémántmentes tartomány  
← 16 mm →

Szinkódolás	FS3-M	FS3-F	FS3-SF
Vastagság mm	0,13	0,10	0,08
Szélesség (mm)	3,75	3,75	3,75
Hossz mm-ben	147,0	147,0	147,0



REF

<b>FS3-M</b>	
<b>FS3-F</b>	
<b>FS3-SF</b>	

### Szeparáló csík fűrészfogazattal, egyoldali csiszolófelület

**FS3-MX, FS3-FX, FS3-SFX** gyémántmentes tartomány  
← 40 mm → Fűrészfogazás

Szinkódolás	FS3-MX	FS3-FX	FS3-SFX
Vastagság mm	0,13	0,10	0,08
Szélesség (mm)	3,75	3,75	3,75
Hossz mm-ben	147,0	147,0	147,0



REF

<b>FS3-MX</b>	
<b>FS3-FX</b>	
<b>FS3-SFX</b>	



**FS3-X-SO 2 + 4 + 4**

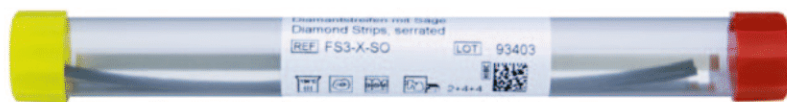

### Szeparáló csík, széles

**FS6-M, FS6-F, FS6-SF**

Szinkódolás	FS6-M	FS6-F	FS6-SF
Vastagság mm	0,13	0,10	0,08
Szélesség (mm)	6,0	6,0	6,0
Hossz mm-ben	147,0	147,0	147,0



REF

<b>FS6-M</b>	
<b>FS6-F</b>	
<b>FS6-SF</b>	



**FS6-SO 2 + 4 + 4**

<b>M</b>	Kék színjelölés	standard	37 - 44 µm	ISO 524
<b>F</b>	Piros színjelölés	finom	30 - 40 µm	ISO 514
<b>SF</b>	Sárga színjelölés	szuperfinom	10 - 20 µm	ISO 504

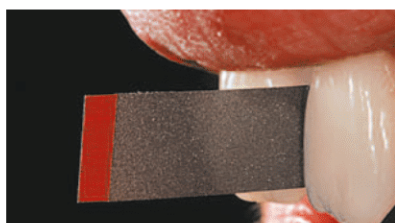
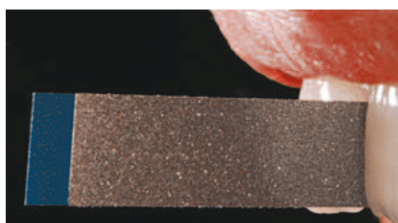

## Szeparáló csík fűrészfogazat nélkül



### FS2-MP, FS2-FP, FS2-SFP

gyémántmentes tartomány

← 16 mm →

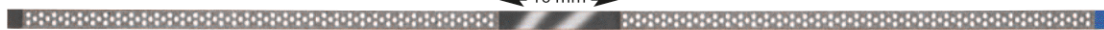

Színkódolás

Vastagság mm	0,13	0,10	0,08
Szélesség (mm)	2,5	2,5	2,5
Hossz mm-ben	147,0	147,0	147,0



REF

	<b>FS2 - MP</b>	
	<b>FS2 - FP</b>	
	<b>FS2 - SFP</b>	



### FS3-MP, FS3-FP, FS3-SFP

gyémántmentes tartomány

← 16 mm →



Színkódolás

Vastagság mm	0,13	0,10	0,08
Szélesség (mm)	3,75	3,75	3,75
Hossz mm-ben	147,0	147,0	147,0



REF

	<b>FS3 - MP</b>	
	<b>FS3 - FP</b>	
	<b>FS3 - SFP</b>	



2+4+4 **FS3-P-SO 2 + 4 + 4**



### FS3-MXP, FS3-FXP, FS3-SFXP

gyémántmentes tartomány

← 40 mm →

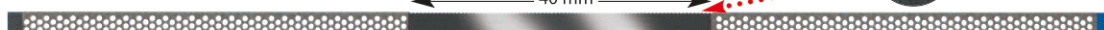

Színkódolás

Vastagság mm	0,13	0,10	0,08
Szélesség (mm)	3,75	3,75	3,75
Hossz mm-ben	147,0	147,0	147,0



REF

	<b>FS3 - MXP</b>	
	<b>FS3 - FXP</b>	
	<b>FS3 - SFXP</b>	



2+4+4 **FS3-XP-SO 2 + 4 + 4**

## Szeparáló csík, széles



### FS6-MP, FS6-FP, FS6-SFP



Színkódolás

Vastagság mm	0,13	0,10	0,08
Szélesség (mm)	6,0	6,0	6,0
Hossz mm-ben	147,0	147,0	147,0



REF

	<b>FS6 - M</b>	
	<b>FS6 - F</b>	
	<b>FS6 - SF</b>	



2+4+4 **FS6-SO 2 + 4 + 4**







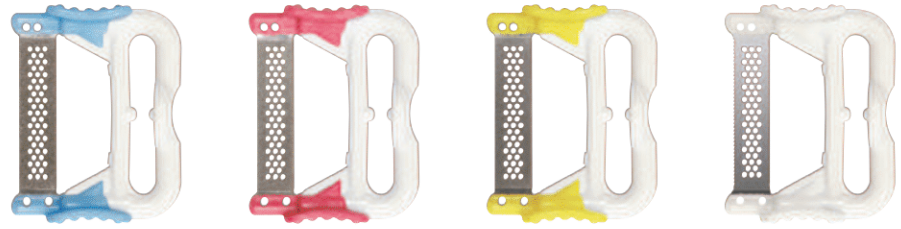



**ProxyStrip utántöltő csomagok**



**FS5-MKP, FS5-FKP,  
FS5-SFKP, FS5-XKP**



Színkódolás

				
Vastagság (mm)	0,13	0,10	0,08	0,04
Szélesség (mm)	5,0	5,0	5,0	5,0
Hossz mm-ben	21,0	21,0	21,0	21,0
REF	 10	 10	 10	 5
 <b>FS5-MKP</b>				
 <b>FS5-FKP</b>				
 <b>FS5-SFKP</b>				
<b>FS5-XKP</b> Fűrészfogazás				



**ProxyStrip választék: FS5-KP-SO**

Tartalom: 1 x FSG-1, 2 x FS5-MKP, 1 x FS5-FKP, 1 x FS5-SFKP, 1 x FS5-XKP



ProxyStrip markolat (kicsinyített ábra)









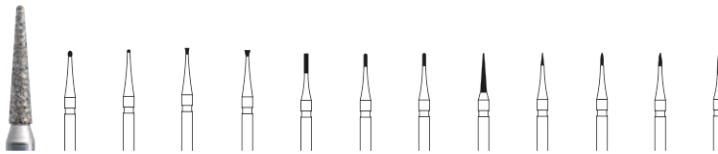









 <b>M</b>	Kék színjelölés	standard	37 - 44 µm	ISO No. 524
 <b>F</b>	Piros színjelölés	finom	30 - 40 µm	ISO No. 514
 <b>SF</b>	Sárga színjelölés	szuperfinom	10 - 20 µm	ISO No. 504

**Kiddies Gyermekeknek kifejlesztett, a minimális invazív**



**Kiddies**  
Gyermekfogászati  
fúrók szemcsézete:  
ISO 514  
62-74 µm



	009	007	008	010	008	007	007	012	007	007	007	007	
Átmérő mérete 1/10 mm	0,9	0,7	0,8	1,0	0,8	0,7	0,7	1,2	0,7	0,7	0,7	0,7	
Hossz mm-ben	1,0	-	1,0	1,0	3,0	2,0	3,5	6,0	2,0	2,0	2,0	3,5	
REF													
FGM  <b>379-</b>	<b>009</b>												<b>M-KID</b>
FG  <b>379-</b>	<b>009</b>												<b>M-KIDL</b>
FGM  <b>801-</b>	<b>007</b>												<b>M-KID</b>
FG  <b>801-</b>	<b>007</b>												<b>M-KIDL</b>
FGM  <b>805-</b>		<b>008</b>											<b>M-KID</b>
FGM  <b>805-</b>			<b>010</b>										<b>M-KID</b>
FGM  <b>835-</b>				<b>008</b>									<b>M-KID</b>
FGM  <b>838-</b>					<b>007</b>								<b>M-KID</b>
FG  <b>838-</b>					<b>007</b>								<b>M-KIDL</b>
FGM  <b>838L-</b>						<b>007</b>							<b>M-KID</b>
FG  <b>838L-</b>						<b>007</b>							<b>M-KIDL</b>
FGM  <b>846-</b>							<b>012</b>						<b>M-KID</b>
FGM  <b>852-</b>								<b>007</b>					<b>M-KID</b>
FGM  <b>860-</b>									<b>007</b>				<b>M-KID</b>
FG  <b>860-</b>									<b>007</b>				<b>M-KIDL</b>
FGM  <b>883-</b>										<b>007</b>			<b>M-KID</b>
FG  <b>883-</b>										<b>007</b>			<b>M-KIDL</b>
FGM  <b>889-</b>											<b>007</b>		<b>M-KID</b>
FG  <b>889-</b>											<b>007</b>		<b>M-KIDL</b>

opt. 160.000 rpm

KID  $\triangle$  ISO 313 (L= 16,5mm)

KIDL  $\triangle$  ISO 314 (L= 19mm)



**KIDL**  
REF SET - 1667

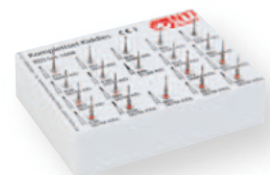

**KID + KIDL**  
REF SET - 1668



**KID**  
REF SET - 1669

## MF-Cut Multifunkcionális koronafelvágó



### H31RMF (137)

Legömbölyített cilinder



Átmérő mérete 1/10 mm	010	012
Hossz mm-ben	42	42

5	REF	US. No.	1557MF	1558MF
H31RMF-		010	012	-FG

opt. 60.000 rpm



### H7MF (232)

Körte



Átmérő mérete 1/10 mm	008
Hossz mm-ben	1,6

5	REF	US. No.	330MF
H7MF-		008	-FG

opt. 60.000 rpm



### H245MF (234)

Körte



Átmérő mérete 1/10 mm	008
Hossz mm-ben	2,8

5	REF	US. No.	245MF
H245MF-		008	-FG

opt. 60.000 rpm



### H31MF (107)

Cilinder



Átmérő mérete 1/10 mm	010
Hossz mm-ben	42

5	REF	US. No.	557MF
H31MF-		010	-FG

opt. 60.000 rpm



### H34

Henger gömbölyű



Átmérő mérete 1/10 mm	010	012
Hossz mm-ben	2,1	2,1

5	REF	H34-	010	012	-FG
25	H34-	010	012	-SET	

opt. 120.000 rpm



### H34L

Henger gömbölyű, hosszú



Átmérő mérete 1/10 mm	010	012
Hossz mm-ben	3,5	3,5

5	REF	H34L-	010	012	-FG
25	H34L-	010	012	-SET	

opt. 120.000 rpm



### G5114-RA

Koronafelvágó



Átmérő mérete 1/10 mm	008
Hossz mm-ben	0,5

1	REF	G5114-RA
---	-----	----------

max. 10.000 rpm



### H4KMK

Henger gömbölyű



Átmérő mérete 1/10 mm	010	012
Hossz mm-ben	2,1	2,1

5	REF	H4KMK-	010	012	-FG
---	-----	--------	-----	-----	-----

opt. 120.000 rpm



### H4KMKL

Henger gömbölyű, hosszú



Átmérő mérete 1/10 mm	012
Hossz mm-ben	3,5

5	REF	H4KMKL-	012	-FG
25	H4KMKL-	012	-SET	

opt. 120.000 rpm

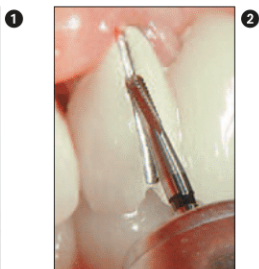

- 1 Kerámiát gyémánt csiszolóeszközzel vágunk.
- 2 Fémét H34-el vágunk.

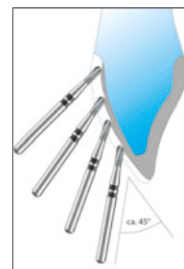
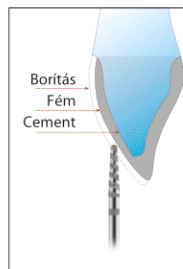

Koronák és hidak felvágásakor kérjük ügyeljen a következőkre:

- 1 A kerámiaborítást egy gyémánteszközzel kell felvágni.
- 2 A fémvázat több munkafázisban, kisebb részdarabok többszöri szétdarabolása útján felvágjuk.

Maximális fordulatszám: 120.000 - 160.000 fordult/perc, nyomóerő: 0,5 N.

**A 45°-os kezdeti szöget figyelembe kell venni!**

## Keményfém fúró

### H1 (001)

Gömbölyű





Átmérő mérete 1/10 mm		005	006	008	010	012	014	016	018	021	023	027	
Hossz mm-ben													
 REF													
US. No.		1/4	1/2	1	2	3	4	5	6	7	8	10	
H1-		005	006	008	010		014		018		023		-FG
H1-			006	008	010	012	014	016	018	021	023	027	-RA

FG  opt. 160.000 rpm RA  opt. 5.000 - 40.000 rpm

### H1S (001)

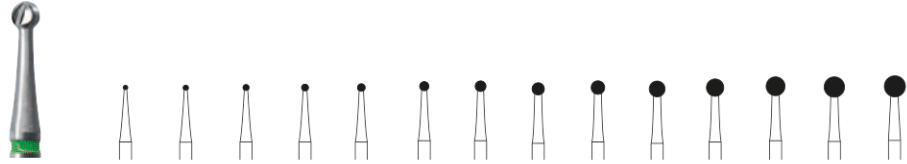
Gömbölyű, jól vágó





Átmérő mérete 1/10 mm		006	007	008	009	010	012	014	016	018	021	023	025	027	029	
Hossz mm-ben																
 REF																
US. No.		1/25		15		25	35	45	55	65	75	85	95	105		
H1S-		006	007	008	009	010	012	014	016	018	021	023				-FG
H1S-						010	012	014	016	018	021	023				-FGXL
H1S-						010		014		018						-FGXXL
H1S-						010	012	014	016	018	021	023	025	027	029	-RA
H1S-							012	014	016	018	021	023				-RAL

 opt. 160.000 rpm FG/FGXL/FGXXL  opt. 8.000-10.000 rpm RA/RAL

### H1SX (001)

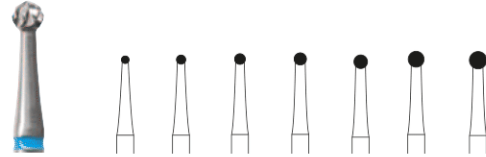
Gömbölyű, keresztmintás





Átmérő mérete 1/10 mm		010	012	014	016	018	021	023	
Hossz mm-ben									
 REF									
US. No.		25X	35X	45X	55X	65X	75X	85X	
H1SX-		010	012	014	016	018	021	023	-RA
H1SX-			012	014	016	018	021	023	-RAL

 opt. 8.000-10.000 rpm

### H1SXN (001)

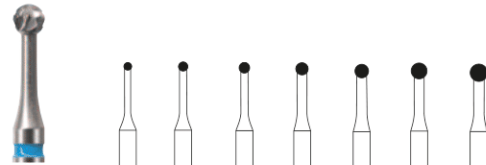
Gömbölyű, keresztmintás  
Vékony nyak



Átmérő mérete 1/10 mm		010	012	014	016	018	021	023	
Hossz mm-ben									
 REF									
US. No.		25XN	35XN	45XN	55XN	65XN	75XN	85XN	
H1SXN-		010	012	014	016	018	021	023	-RA
H1SXN-		010		014		018		023	-RAL

 opt. 1.000 - 1.500 rpm



**Eltávolító a fogszuvasodás minimálisan invazív feltáráshoz**

### H2 (010)

Fordított kúp

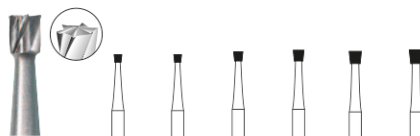



Átmérő mérete 1/10 mm		008	010	012	014	016	018	
Hossz mm-ben		0,8	1,0	1,2	1,4	1,6	1,7	
 REF								
US. No.		34	35	36	37	38	39	
H2-		008	010		014			-FG
H2-			010	012	014	016	018	-RA

FG  opt. 160.000 rpm RA  opt. 5.000 - 40.000 rpm

### H1SF (004)

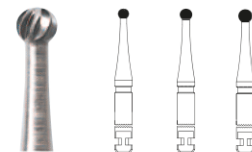
Gömbölyű



Átmérő mérete 1/10 mm		014	016	018	
Hossz mm-ben					
 REF					
H1SF-		014	016	018	-RA

 opt. 1.500 - 2.000 rpm





**H7  
(232)**



Körte

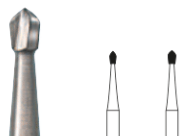

Átmérő mérete 1/10 mm	008	010	
Hossz mm-ben	1,6	1,7	
5	REF		
US. No.	330	331	
	<b>H7-</b>	<b>008 010</b>	<b>-FG</b>

opt. 160.000 rpm

**H21  
(107)**



Henger

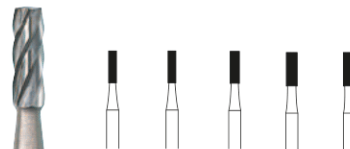

Átmérő mérete 1/10 mm	009	010	012	014	016
Hossz mm-ben	4,2	4,2	4,2	4,4	4,4
5	REF				
US. No.	56	57	58	59	60
	<b>H21-</b>	<b>009 010 012</b>			<b>-FG</b>
	<b>H21-</b>	<b>010 012 014 016</b>			<b>-RA</b>

FG opt. 160.000 rpm RA opt. 5.000 - 40.000 rpm

**H21R  
(137)**



Henger, gömbölyű

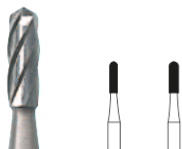

Átmérő mérete 1/10 mm	012	012	
Hossz mm-ben	4,2	4,2	
5	REF		
US. No.	1157	1158	
	<b>H21R-</b>	<b>010 012</b>	<b>-FG</b>

FG opt. 160.000 rpm

**H23R  
(194)**



Kúp, gömbölyű

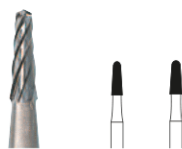

Átmérő mérete 1/10 mm	014	016	
Hossz mm-ben	4,4	4,4	
5	REF		
US. No.	1172		
	<b>H23R-</b>	<b>014 016</b>	<b>-RA</b>

opt. 5.000 - 40.000 rpm

**H31  
(107)**



Henger

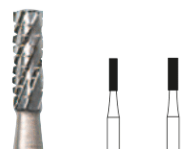

Átmérő mérete 1/10 mm	010	012	
Hossz mm-ben	4,2	4,2	
5	REF		
US. No.	557	558	
	<b>H31-</b>	<b>010 012</b>	<b>-FG</b>
	<b>H31-</b>	<b>010</b>	<b>-RA</b>

FG opt. 160.000 rpm RA opt. 5.000 - 40.000 rpm

**Fogszabályozás  
Tömés- és ragasztóanyag eltávolító**

**T21RX  
(137)**



Henger gömbölyű



Átmérő mérete 1/10 mm	010	012	
Hossz mm-ben	4,2	4,2	
5	REF		
	<b>T21RX-</b>	<b>010 012</b>	<b>-FG</b>
	<b>T21RX-</b>	<b>010 012</b>	<b>-RA</b>

opt. FG 160.000 rpm, RA 30.000 rpm

**T21X  
(107)**



Amalgám eltávolító,  
henger



Átmérő mérete 1/10 mm	010	012	
Hossz mm-ben	4,2	4,2	
5	REF		
	<b>T21X-</b>	<b>010 012</b>	<b>-FG</b>

opt. 160.000 rpm

**T7LX  
(234)**



Amalgám eltávolító,  
körte



Átmérő mérete 1/10 mm	010	012	
Hossz mm-ben	4,2	4,4	
5	REF		
	<b>T7LX-</b>	<b>012 014</b>	<b>-FG</b>

opt. 160.000 rpm

## Tömés- és ragasztóanyag eltávolító

**T23RX (194)**  
Amalgám eltávolító  
kúpos, gömbölyű



Átmérő mérete 1/10 mm	012	
Hossz mm-ben	4,2	
 5	REF	
<b>T23RX- 012 -FG</b>		

opt. 160.000 rpm

**T379X (277)**  
Tojásdad



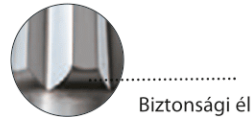

Átmérő mérete 1/10 mm	018	023
Hossz mm-ben	3,5	4,2
 5	REF	
<b>T379X- 018 023 -RA</b>		

opt. 30.000 rpm



**H22GK (217)**



Átmérő mérete 1/10 mm	016	
Hossz mm-ben	4,7	
 5	REF	
<b>H22GK- 016 -FG</b>		

opt. 160.000 rpm

**H22AGK (217)**



Átmérő mérete 1/10 mm	016	
Hossz mm-ben	4,7	
 5	REF	
<b>H22AGK- 016 -FG</b>		
<b>H22AGK- 016 -RA</b>		

opt. FG 160.000 rpm, RA 30.000 rpm

**H22ALGK (219)**



Átmérő mérete 1/10 mm	016	
Hossz mm-ben	8,0	
 5	REF	
<b>H22ALGK- 016 -FG</b>		
<b>H22ALGK- 016 -RA</b>		

opt. FG 160.000 rpm, RA 30.000 rpm

## Hartmetallfinierer

### Titán fogpillér készítése

**H379G (277)**  
Tojásdad



Átmérő mérete 1/10 mm	03	
Hossz mm-ben	4,0	
 5	REF	
<b>H379G- 023 -FG</b>		

opt. 160.000 rpm

**H847KRG (546)**  
Kúp,  
gömbölyű munkaél



Átmérő mérete 1/10 mm	016	
Hossz mm-ben	8,0	
 5	REF	
<b>H847KRG- 016 -FG</b>		

opt. 160.000 rpm

**H856G (198)**  
Kúp, gömbölyű



Átmérő mérete 1/10 mm	016	
Hossz mm-ben	8,0	
 5	REF	
<b>H856G- 016 -FG</b>		

opt. 160.000 rpm

**H379 (277)**  
Tojásdad



Átmérő mérete 1/10 mm	023	
Hossz mm-ben	4,2	
 5	REF	
US. No.	7408	
<b>H379- 023(12) -FG</b>		

opt. 160.000 rpm

**H336 (546)**  
Kúp,  
gömbölyű munkaél

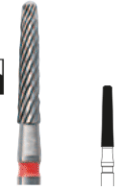

Átmérő mérete 1/10 mm	016	
Hossz mm-ben	8,0	
 5	REF	
<b>H336- 016(12) -FG</b>		

opt. 160.000 rpm

**H375R (198)**  
Kúp, gömbölyű



Átmérő mérete 1/10 mm	016	
Hossz mm-ben	8,0	
 5	REF	
US. No.	7675	
<b>H375R- 016(12) -FG</b>		

opt. 160.000 rpm

	... piros gyűrű	standard	ISO No. 071 - 072	(..) = az élek száma
	... F sárga gyűrű	finom	ISO No. 041	
	... UF fehér gyűrű	ultrafinom	ISO No. 031	

## Egylépcsős polírozó

### H48LS (249)

Láng, hosszú

Átmérő mérete 1/10 mm	012
Hossz mm-ben	8,0
5	REF
H48LS-	012(12) -FG

opt. 20.000 rpm

### H134S (164)

Kúpos, hegyes; inykimélő biztonsági csúcs

Átmérő mérete 1/10 mm	014
Hossz mm-ben	6,0
5	REF
H134S-	014(15) -FG

opt. 20.000 rpm



### H135S (166)

Kúpos, hegyes; inykimélő biztonsági csúcs

Átmérő mérete 1/10 mm	014
Hossz mm-ben	9,0
5	REF
H135S-	014(15) -FG

opt. 20.000 rpm

### H379S (277)

Tojásdad

Átmérő mérete 1/10 mm	023
Hossz mm-ben	4,2
5	REF
H379S-	023(16) -FG

opt. 20.000 rpm

### H390S (274)

Lövedék

Átmérő mérete 1/10 mm	018
Hossz mm-ben	3,7
5	REF
H390S-	018(16) -FG

opt. 20.000 rpm

(..) = az élek száma

## Keményfém – finiselők

A TDF (Top Definiált Finiselés) jelöléssel rendelkező eszközök gyémántozott kivitelben is kaphatók.

### H132 (699) TDF

Kúpos, hegyes; inykimélő biztonsági csúcs

Átmérő mérete 1/10 mm	008
Hossz mm-ben	3,0
5	REF
H132-	008(8) -FG

opt. 160.000 rpm

### H133 (159) TDF

Kúpos, hegyes; inykimélő biztonsági csúcs

Átmérő mérete 1/10 mm	010
Hossz mm-ben	4,2
5	REF
H133-	010(8) -FG
H133F-	010(16) -FG

opt. 160.000 rpm

### H134 (164) TDF

Kúpos, hegyes; inykimélő biztonsági csúcs

Átmérő mérete 1/10 mm	014
Hossz mm-ben	6,0
5	REF
H134-	014(8) -FG
H134F-	014(16) -FG
H134UF-	014(30) -FG

opt. 160.000 rpm

### H135 (166) TDF

Kúpos, hegyes; inykimélő biztonsági csúcs

Átmérő mérete 1/10 mm	014
Hossz mm-ben	9,0
5	REF
H135-	014(8) -FG
H135F-	014(16) -FG
H135UF-	014(30) -FG

opt. 160.000 rpm

### H246 (495)

Láng

Átmérő mérete 1/10 mm	009	010	012
Hossz mm-ben	3,6	3,6	3,7
5	REF		
H246-	009(12)	010(12)	012(12)

opt. 160.000 rpm

### H246L (496)

Láng

Átmérő mérete 1/10 mm	012
Hossz mm-ben	5,4
5	REF
H246L-	012(12) -FG

opt. 160.000 rpm

... piros gyűrű  
 ... F sárga gyűrű  
 ... UF fehér gyűrű

standard ISO No. 071 - 072  
 finom ISO No. 041  
 ultrafinom ISO No. 031

(..) = az élek száma



## H375R (198)

Kúp, gömbölyű

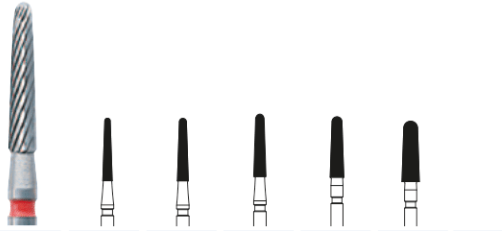

Átmérő mérete 1/10 mm	012	014	016	018	023
Hossz mm-ben	8,0	8,0	8,0	8,0	8,0
5	REF				
US. No.	7653	7664	7675	7686	
H375R-	012(12)	014(12)	016(12)	018(12)	023(12) -FG

opt. 160.000 rpm



## H282 (288)

Kúpos, gömbölyű

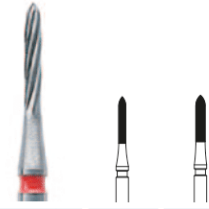

Átmérő mérete 1/10 mm	010	012
Hossz mm-ben	6,0	6,0
5	REF	
H282-	010(8)	-FG
H282-	010(8)	012(10) -RA

opt. FG 160.000 rpm, RA/CA 30.000 rpm



## H46 (254)

Flamme

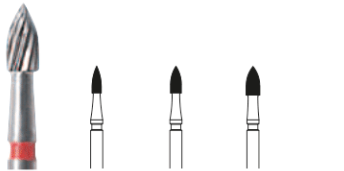

Átmérő mérete 1/10 mm	012	014	018
Hossz mm-ben	3,5	3,5	3,8
5	REF		
US. No.	7102	7104	7106
H46-	012(12)	014(12)	018(12) -FG

opt. FG 160.000 rpm, RA 30.000 rpm



## H282K (297)

Torpedó



Átmérő mérete 1/10 mm	014
Hossz mm-ben	6,0
5	REF
H282K-	014(12) -FG

opt. 160.000 rpm



## H379 (277)

Tojásdad



Átmérő mérete 1/10 mm	012	014	018	023
Hossz mm-ben	3,1	3,1	3,5	4,2
5	REF			
US. No.	7404	7406	7408	
H379-	012(12)	014(12)	018(12)	023(12) -FG
H379F-				023(20) -FG
H379UF-	014(30)	018(30)	023(30)	-FG
H379-	014(12)		023(12)	-FGXXL
H379UF-	014(30)		023(30)	-FGXXL
H379-		018(12)	023(12)	-RA

opt. FG 160.000 rpm, FGXXL 40.000 rpm, RA 30.000 rpm



## H48L (249)

Láng, hosszú

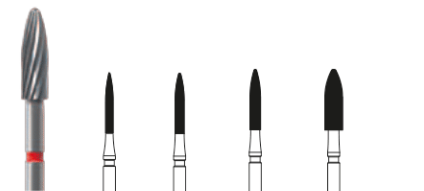

Átmérő mérete 1/10 mm	010	012	014	023
Hossz mm-ben	8,0	8,0	8,0	8,0
5	REF			
H48L-	010(12)	012(12)		-FG
H48LF-		012(20)		-FG
H48LUF-		012(30)		-FG
H48L-		014(12)	023(12)	-FGXXL
H48LUF-		014(30)	023(30)	-FGXXL

opt. 160.000 rpm, FGXXL 40.000 rpm

	...	piros gyűrű	standard	ISO No. 071 - 072	(..) = az élek száma
	... F	sárga gyűrű	finom	ISO No. 041	
	... UF	fehér gyűrű	ultrafinom	ISO No. 031	

NTi Endo Clean



**NT04-...**  
Endo-reszelők

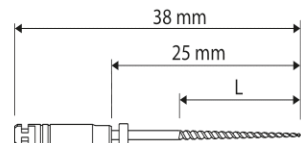

Méret	ø 1/100 mm	020	025	030	035
	L mm	16	16	16	16

REF	NT04-	020	025	030	035
-----	-------	-----	-----	-----	-----

max. 300 rpm



**ST10-...**  
Reamer

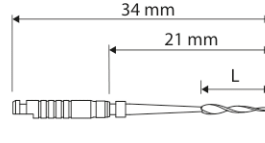

Nyeljelölő gyűrűk	5	
	L mm	9,1

REF	ST10-	035
-----	-------	-----

max. 300 rpm



**NT06-...**  
Endo-reszelők

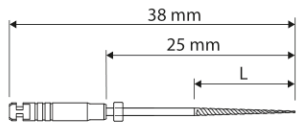

Méret	ø 1/100 mm	020	025	030	035
	L mm	13	12	11	10

REF	NT06-	020	025	030	035
-----	-------	-----	-----	-----	-----

max. 300 rpm



Használjon nyomaték-szabályozóval ellátott motort  
Az alábbi forgatónyomatékkal rendelkező motorok  
NT04 = 1,5 - 1,8 Ncm,  
NT06 = 2,4 - 2,9 Ncm  
csak csekély üzemi nyomáson működnek.

REF Set-Endo1 = 180.15.050 / 180.15.070 / 180.15.090 / 173.25.654.015 / NT04-020 / NT04-025 / NT04-035



REF Set-Endo2 = 173.25.654.015 / NT06-025 / NT04-025 / NT04-035

**H152 (210)**  
Kúpos, extra



Átmérő mérete 1/10 mm	009
Hossz mm-ben	9,0

REF	H152-	009	-FG
	H152-	009	-FGL

opt. 120.000 rpm

**802L (494)**  
Gömbölyű, hosszított nyakkal

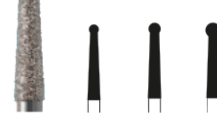

Átmérő mérete 1/10 mm	013	016	021
Hossz mm-ben	10,0	10,0	10,0

REF	802L-	013	016	021	M-FG
-----	-------	-----	-----	-----	------

opt. 013 - 016 = 120.000 rpm, 021 = opt. 160.000 rpm

Csak piros sarokelem használatával

Endo-Access-készlet

REF Set-1654.1

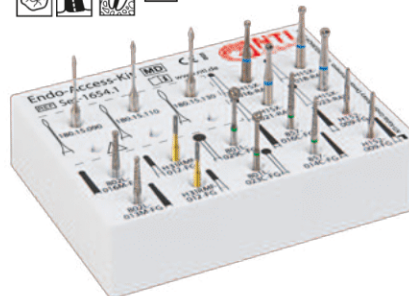

Müller-féle keményfém fúró, endodoncia

**H1SNL (001)**  
Gömbölyű, Vékony nyak

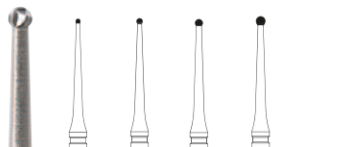

Átmérő mérete 1/10 mm	006	008	010	012
Hossz mm-ben				

REF	H1SNL-	006	008	010	012	-RAL
-----	--------	-----	-----	-----	-----	------

opt. 1.500 - 2.000 rpm

**H1SEB (004)**  
Gömbölyű, Vékony nyak

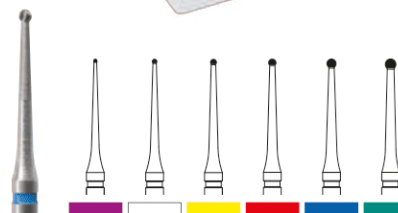

Átmérő mérete 1/10 mm	004	006	008	010	012	014
Hossz mm-ben	0,4	0,6	0,8	1,0	1,2	1,4

REF	H1SEB-	004	006	008	010	012	014	-RAL
	H1SEB-	004	006	008	010	012	014	-RALX

opt. 1.500 rpm

## Gyémánt gömbök a sebészetben

Gyémánt gömböket évek óta sikeresen használnak a sebészetben.

A közepes szemcsézettség lehetővé teszi mind a hidak bevonásához történő használatukat az ínyformázás során, mind pedig a biztonságos vágási teljesítményt az ablak technika alkalmazásakor.

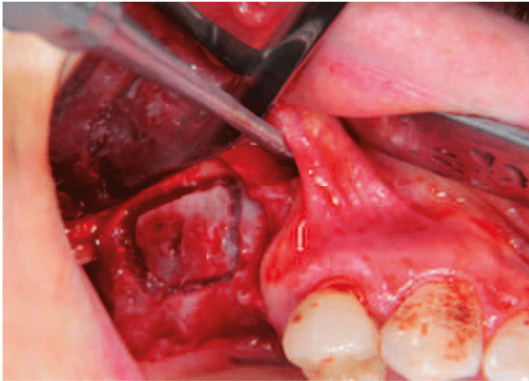

**C801**   
**(001)**

Gömbölyű

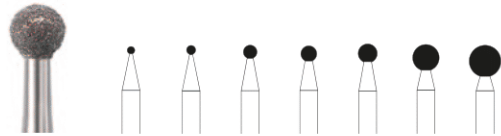

Átmérő mérete 1/10 mm	010	012	018	023	025	035	042		
Hossz mm-ben									
 3	<b>REF</b>								
	<b>C801-</b>	<b>010</b>	<b>012</b>	<b>018</b>	<b>023</b>	<b>025</b>	<b>035</b>	<b>042</b>	<b>M-HP</b>

opt. 8.000 rpm

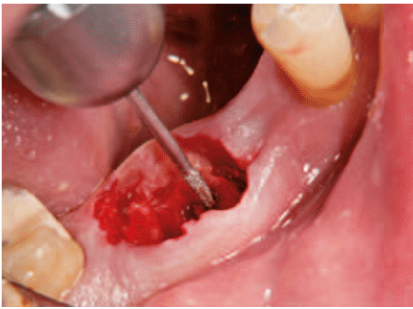

CDS2-014M-FGXXL

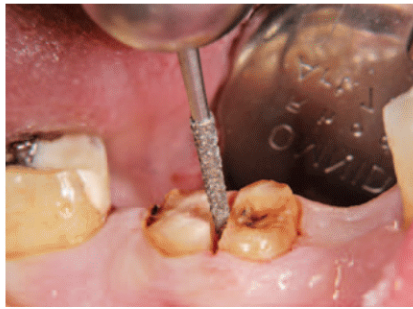

CDS2-016C-FGXXL

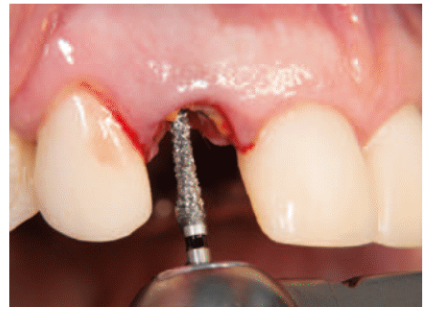

CDS1-018SC-FG

## ChirDia 2

Az ismert ChirDia alkalmazási területét bővíti a kétféle szemcseszerkezettel kapható, gyémánt bevonatú sebészeti eszközök.

Az egyes alkatrészek finom kialakítása mindenekelőtt a mélyen fekvő kis gyökérdarabok biztonságos eltávolítását teszi lehetővé az alveolákból. A hosszú, vékony nyak megkönnyíti a betekintést a fogmeder mélyébe. A közepes szem-

csézettség és a durva szemcsézettség közötti választás lehetősége segíti az igény szerinti célzott alkalmazást.

A vágáshoz igen alkalmas durva szemcseszerkezet gyors és a pácienset kímélő gyökércsúcs-csonkolást tesz lehetővé. A kiegészítő külső hűtés, valamint az UniMatrix® gyémánt bevonatban kialakított elvezető térközzök a fog keményszövetekinek csontállományt kímélő csiszolását biztosítják.

### CDS2 (415)



Gyémánt bevonatú sebészeti eszköz



Átmérő mérete 1/10 mm	014
Hossz mm-ben	6,0

3	REF	CDS2-	014	M-FGXXL
---	-----	-------	-----	---------

opt. 80.000 rpm, max. 100.000 rpm

### CDS2 (199)



Gyémánt bevonatú sebészeti eszköz



Átmérő mérete 1/10 mm	016
Hossz mm-ben	6,0

3	REF	CDS2-	016	C-FGXXL
---	-----	-------	-----	---------

opt. 80.000 rpm, max. 100.000 rpm

## ChirDia Sebészeti eszközök, gyémánttal

### CDS1 (411)



Átmérő mérete 1/10 mm	016	018	021
Hossz mm-ben	12,0	12,0	12,0

3	REF	CDS1-	016	018	021	C-FG
		CDS1-	016	018	021	C-FGL
		CDS1-	016	018	021	SC-FG
		CDS1-	016	018	021	SC-FGL

### CDS1 (411)

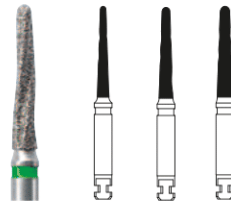

Átmérő mérete 1/10 mm	018	021	023
Hossz mm-ben	12,0	12,0	12,0

3	REF	CDS1-	018	021	023	C-RA
---	-----	-------	-----	-----	-----	------

### CDS1 (411)

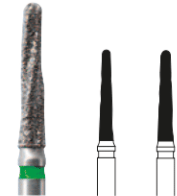

Átmérő mérete 1/10 mm	021	023
Hossz mm-ben	12,0	12,0

3	REF	CDS1-	021	023	C-HP
---	-----	-------	-----	-----	------

Fordulatszám: opt. FG 100.000 rpm piros sarokelem használatával

tömött csontállomány: opt. RA 20.000 rpm

opt. HP 10.000 - 30.000 rpm

Szivacsos: opt. FG 30.000 rpm piros sarokelem használatával

csontállomány: opt. RA 10.000 rpm

opt. HP 10.000 rpm

FG-szár a piros, sebészeti könyökdarabban való használathoz.

A munka során gondoskodjon a megfelelő hűtésről, mélyen, a csontban végzett munka esetén pedig további hűtésről.

1:1 alakrajzok

## Sebészeti műszerek titán-nitrid bevonatú keményfém

**H162C  
(408)**



Csontfúró

Átmérő mérete 1/10 mm	016
Hossz mm-ben	10,0



REF

**H162C- 016 -FGXL**

⌚ opt. 6.000 rpm

**H166SC  
(409)**



Csontfúró

Átmérő mérete 1/10 mm	021
Hossz mm-ben	10,0



REF

**H166SC- 021 -HP**

⌚ opt. 1.500 rpm

**H254AC  
(415)**



Csontfúró

Átmérő mérete 1/10 mm	012
Hossz mm-ben	6,0



REF

**H254AC- 012 -FGXXL**

⌚ opt. 80.000 rpm

## Trianguláris eszköz

**RF186  
(684)**



Frézer

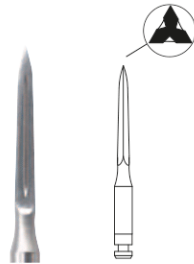

Átmérő mérete 1/10 mm	018
Hossz mm-ben	13,2



REF

**RF186- 018 -HP**

**RF186- 018 -RA**

⌚ opt. 2.500 rpm

**RF186LM  
(684)**



Frézer

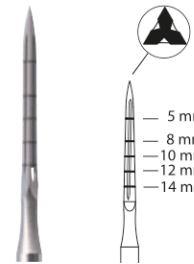

— 5 mm  
— 8 mm  
— 10 mm  
— 12 mm  
— 14 mm

Átmérő mérete 1/10 mm	018
Hossz mm-ben	16,0



REF

**RF186LM- 018 -RAXL**

⌚ opt. 1.000 rpm

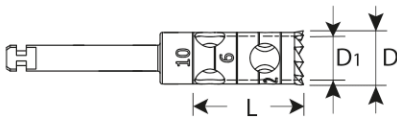

**RF229  
(486)**



Trepánfúró rozsdamentes acélból

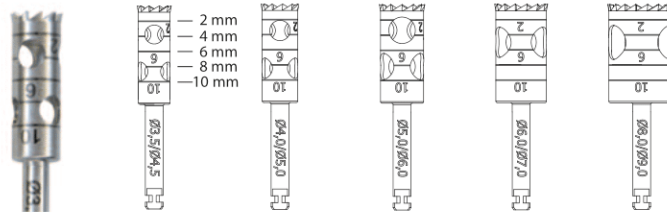

Méret L mm	10,0	10,0	10,0	10,0	10,0
D1 $\varnothing$ 1/10 mm	035	040	050	060	080
D $\varnothing$ 1/10 mm → ←	045	050	060	070	090



REF

**RF229- 035 040 050 060 080 -RAL**

⌚ opt. 1.000 rpm / 050 - 080 ⌚ opt. 500 rpm



REF RF229L-040-RAL



## Trepánfúró

### RF229L (555)

Trepánfúró rozsdamentes acélból, hosszú

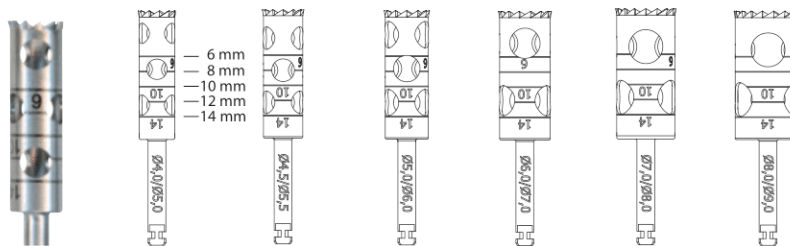

Méret L mm	14,0	14,0	14,0	14,0	14,0	14,0	
D1 $\varnothing$ 1/10 mm	040	045	050	060	070	080	
D $\varnothing$ 1/10 mm →↔←	050	055	060	070	080	090	
REF	040	045	050	060	070	080	-RAL

↻ opt. 1.000 rpm / 050 - 080 ↻ opt. 500 rpm

## Pilótafúró

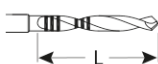

### RF210 (428)

Pilótafúró rozsdamentes acélból, az implantológia számára

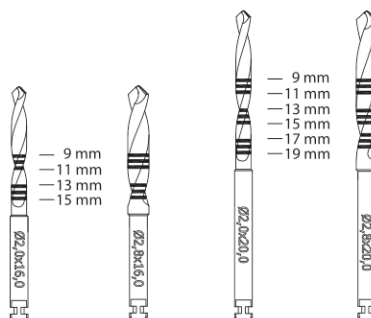

Átmérő mérete 1/10 mm	1020	028	020	028	
Hossz mm-ben	16,0	16,0	20,0	20,0	
REF	020	028	020	028	-RAL
	RF210L-				-RAL

↻ opt. 1.000 rpm, ↻ max. 6.000 rpm



### RF210LM1 (428)

Pilótafúró rozsdamentes acélból, az implantológia számára

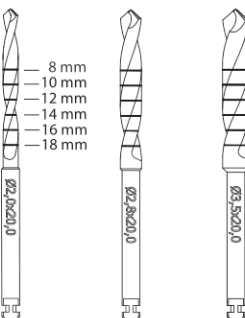

Átmérő mérete 1/10 mm	020	028	035	
Hossz mm-ben	20,0	20,0	20,0	
REF	020	028	035	-RAL
	RF210LM1-			

↻ opt. 800 rpm ISO 020, 700 rpm ISO 028, 600 rpm ISO 035

**Keményfém eszközök**



**H141AX  
(001) ALLPORT**

Csontfúró

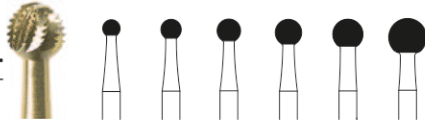

Átmérő mérete 1/10 mm	023	027	031	035	040	050	
Hossz mm-ben							
 3	REF						
<b>H141AX-</b>	<b>023</b>	<b>027</b>	<b>031</b>	<b>035</b>	<b>040</b>	<b>050</b>	<b>-HP</b>
<b>H141AX-</b>	<b>023</b>	<b>027</b>	<b>031</b>	<b>035</b>	<b>040</b>		<b>-RAL</b>
<b>H141AX-</b>	<b>023</b>	<b>027</b>	<b>031</b>	<b>035</b>	<b>040</b>	<b>050</b>	<b>-RAXL</b>

opt. 6.000 rpm



**H254A  
(415)**

Csontfúró

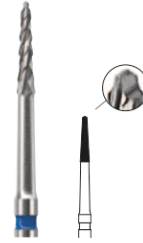

Átmérő mérete 1/10 mm	012	
Hossz mm-ben	6,0	
 3	REF	
<b>H254A-</b>	<b>012</b>	<b>-FGXL</b>
<b>H254A-</b>	<b>012</b>	<b>-FGXL</b>
opt. 80.000 rpm		
<b>H254A-</b>	<b>012</b>	<b>-HP</b>
<b>H254A-</b>	<b>012</b>	<b>-RAL</b>
<b>H254A-</b>	<b>012</b>	<b>-RAXL</b>

opt. 40.000 rpm



**H141  
ALLPORT**

Csontfúró

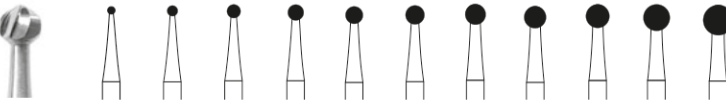

Átmérő mérete 1/10 mm	010	014	018	021	023	025	027	029	031	035	040	
Hossz mm-ben												
 3	REF											
<b>H141-</b>	<b>010</b>	<b>014</b>	<b>018</b>		<b>023</b>	<b>025</b>	<b>027</b>	<b>029</b>	<b>031</b>	<b>035</b>	<b>040</b>	<b>-HP</b>
<b>H141-</b>	<b>010</b>	<b>014</b>	<b>018</b>		<b>023</b>	<b>025</b>						<b>-RAL</b>
<b>H141-</b>		<b>014</b>	<b>018</b>		<b>023</b>							<b>-RAXL</b>
<b>H141-</b>		<b>014</b>	<b>018</b>	<b>021</b>	<b>023</b>							<b>-FGXL</b>

opt. 1.500 rpm, FGXL opt. 100.000 rpm



**H141A  
ALLPORT**

Csontfúró

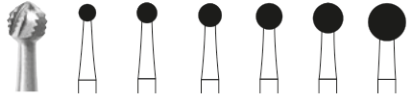

Átmérő mérete 1/10 mm	023	027	031	035	040	050	
Hossz mm-ben							
 3	REF						
<b>H141A-</b>	<b>023</b>	<b>027</b>	<b>031</b>	<b>035</b>	<b>040</b>	<b>050</b>	<b>-HP</b>
<b>H141A-</b>	<b>023</b>						<b>-RAL</b>
<b>H141A-</b>	<b>023</b>			<b>035</b>			<b>-RAXL</b>

opt. 1.500 rpm



**H267**

Csontfúró



Átmérő mérete 1/10 mm	016	
Hossz mm-ben	9,0	
 3	REF	
<b>H267-</b>	<b>016</b>	<b>-FGXL</b>

opt. 75.000 rpm



**H151**

Speciális fúrók



Átmérő mérete 1/10 mm	015	
Hossz mm-ben	11,0	
 3	REF	
<b>H151-</b>	<b>015</b>	<b>-FGXL</b>
<b>H151-</b>	<b>015</b>	<b>-FGXXL</b>

opt. 100.000 rpm



**H269GK  
ENDO**



Átmérő mérete 1/10 mm	016	
Hossz mm-ben	9,0	
 3	REF	
<b>H269GK-</b>	<b>016</b>	<b>-FGXL</b>

opt. 75.000 rpm



**H269  
Speciális fúrók**



Átmérő mérete 1/10 mm	016	
Hossz mm-ben	11,0	
 3	REF	
<b>H269-</b>	<b>016</b>	<b>-HP</b>
<b>H269-</b>	<b>016</b>	<b>-RAXL</b>
<b>H269-</b>	<b>016</b>	<b>-FGXL</b>
<b>H269-</b>	<b>016</b>	<b>-FGXXL</b>

opt. 1.500 rpm, FGXL/FGXXL opt. 75.000 rpm



**H161  
Csontfúró  
LINDEMANN**



Átmérő mérete 1/10 mm	016	
Hossz mm-ben	9,0	
 3	REF	
<b>H161-</b>	<b>016</b>	<b>-HP</b>
<b>H161-</b>	<b>016</b>	<b>-FGXL</b>

opt. 1.500 rpm, FGXL opt. 100.000 rpm



**H162  
Csontfúró  
LINDEMANN**



Átmérő mérete 1/10 mm	016	
Hossz mm-ben	9,0	
 3	REF	
<b>H162-</b>	<b>016</b>	<b>-HP</b>
<b>H162-</b>	<b>016</b>	<b>-RAL</b>
<b>H162-</b>	<b>016</b>	<b>-FGXL</b>

opt. 1.500 rpm, FGXL opt. 100.000 rpm

## Keményfém eszközök



### H166

Csontfúró



Átmérő mérete 1/10 mm	021
Hossz mm-ben	10,0



REF

H166-	021	-HP
H166-	021	-RAL
H166-	021	-RAXL

opt. 1.500 rpm



### H166A

Csontfúró

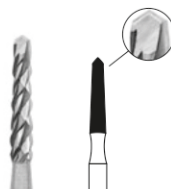

Átmérő mérete 1/10 mm	021
Hossz mm-ben	10,0



REF

H166A-	021	-HP
--------	-----	-----

opt. 1.500 rpm



### H167

Csontfúró



Átmérő mérete 1/10 mm	023
Hossz mm-ben	10,0



REF

H167-	023	-HP
H167-	023	-RAXL

opt. 1.500 rpm



### H162A

Csontfúró



Átmérő mérete 1/10 mm	016
Hossz mm-ben	10,0



REF

H162A-	016	-HP
H162A-	016	-RAXL
H162A-	016	-FGXL
H162A-	016	-FGXXL

opt. 1.500 rpm, FGXL/FGXXL opt. 100.000 rpm



### H560

Endo



Átmérő mérete 1/10 mm	008
Hossz mm-ben	4,0



REF

H560-	008	-FGXXL
-------	-----	--------

opt. 100.000 rpm



### H254

Fúró pengeimplantátumok számára



Átmérő mérete 1/10 mm	010	012
Hossz mm-ben	6,0	6,0



REF

H254-	010	012	-FGXL
H254-	010	012	-FGXXL

opt. 100.000 rpm

## Rozsdamentes acéleszközök = RF



### RF161

Csontfúró  
LINDEMANN



Átmérő mérete 1/10 mm	016
Hossz mm-ben	9,0



REF

RF161-	016	-HP
--------	-----	-----

opt. 1.500 rpm



### RF162

Csontfúró  
LINDEMANN



Átmérő mérete 1/10 mm	016
Hossz mm-ben	9,0



REF

RF162-	016	-FGXL
--------	-----	-------

opt. 75.000 rpm



### RF163

Csontfúró  
LINDEMANN



Átmérő mérete 1/10 mm	014
Hossz mm-ben	5,0



REF

RF163-	014	-FGXL
--------	-----	-------

opt. 1.500 rpm

## Tissue Trimmer

**Felhasználási területek:** Fogínyformálás és fogínyvágás • A tasak kibővítése lenyomatok miatt • Mély fognyaküregek feltárása • Papilla eltávolítása • Csontban levő implantátumok valamint retineált fogak feltárása



**Munka közbeni fordulatszám:** opt. 300.000 - 500.000 fordulat/perc

**Hűtőspray nélkül használható!**



### 249

TissueTrimmer



Átmérő mérete 1/10 mm	016
Hossz mm-ben	5,0

REF

249-	016	-FG
249-	016	-FG2

opt. 300.000 - 500.000 rpm



### 250

TissueTrimmer

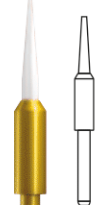

Átmérő mérete 1/10 mm	016
Hossz mm-ben	8,0

REF

250-	016	-FG
250-	016	-FG2

opt. 300.000 - 500.000 rpm



REF Set-1611

**Kompozit polírozók**

2 fokozatú  
polírozó rendszer

Előpolírozás • durva szemcsézettség



Magasfényű polírozás, • finom szemcsézettség



**NTI DiaGloss**

A polírozás folyamán a fog felületén keletkező hő a gumikötés elvezeti, így elkerülhető a túlhevülés.



Átmérő mérete 1/10 mm	050	030	085	060	100	035
Hossz mm-ben	10,0	6,0	7,0	10,0	1,0	6,0
RA  REF	P1932B (6)	P1933B (6)	P1934B (6)	P1935B (6)	P1938B (6)	P1939B (6)
RA  REF	P1932E (25)	P1933E (25)	P1934E (25)	P1935E (25)	P1938E (25)	P1939E (25)
RA  REF	P1932G (100)	P1933G (100)	P1934G (100)	P1935G (100)	P1938G (100)	P1939G (100)

opt. 10.000 rpm





**NTI DiaGloss**

Lamellás polírozó



Átmérő mérete 1/10 mm	130	130
Hossz mm-ben	1,5	1,5

RA  REF	P1039B (6)	P1139B (6)
RA  REF	P1039G (100)	P1139G (100)

opt. 6.000 rpm





**NTI Unique**

Egyfokozatú gyémánt-polírozó kompozit tömésekhez.



ø 1/10 mm	050	030	060	100	130
L (mm-ben)	10,0	6,0	10,0	1,0	1,5

RA  REF	P20032B (6)	P20033B (6)	P20035B (6)	P20038B (6)	20039B (6)
RA  REF	P20032E (25)	P20033E (25)	P20035E (25)	P20038E (25)	20039E (25)
RA  REF	P20032G (100)	P20033G (100)	P20035G (100)	P20038G (100)	20039G (100)

opt. 5.000 rpm

**FlexiPol - Kompozit polírozó korong**



Átmérő (mm)	12	8	12	8
 REF	PC1260	PC1261	PC1270	PC1271
szemcsézettség	durva		közepes	
aktív oldal	egyoldali külső		kétoldali	
felhasználás	kontúrozó		finírozó	

opt. 10.000 - 12.000 rpm



Átmérő (mm)	12	8	12	8	4
 REF	PC1280	PC1281	PC1290	PC1291	M4038
szemcsézettség	finom		ultrafinom		
aktív oldal	kétoldali		kétoldali		
felhasználás	előpolírozó		magas fényű polírozó		

opt. 10.000 - 12.000 rpm



**REF PC1295-Set**

25 polírozóhoz 4 mandrell -típusonként 1 mandrell



Csak vízsprayvel együtt használni!

1. fokozat: Előpolírozás, durva szemcsés  
2. fokozat: Magas fényű polírozás



REF Set-1657

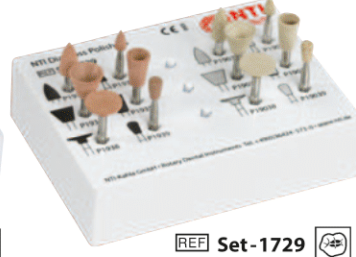

REF Set-1729

**Kompozit polírozó korongok RA**



**NTI BrushGloss**

A rágófelületek tökéletes végpolírozásához. A kefeszál integrált szilíciumkarbid csiszolószemcsékkel készült.



Átmérő mérete 1/10 mm	050	050	070
Hossz mm-ben	6,0	6,0	5,0

RA  REF	P1500	P1501	P1502
--	-------	-------	-------

opt. 3.000 rpm

## Kerámia polírozó

NTI CeraGlaze – tökéletesen alkalmas cirkondioxid megmunkálására.



### NTI CeraGlaze

A polírozás folyamán a fog felületén a keletkező hőt a gumikötés elvezeti, így elkerülhető a túlhevülés.

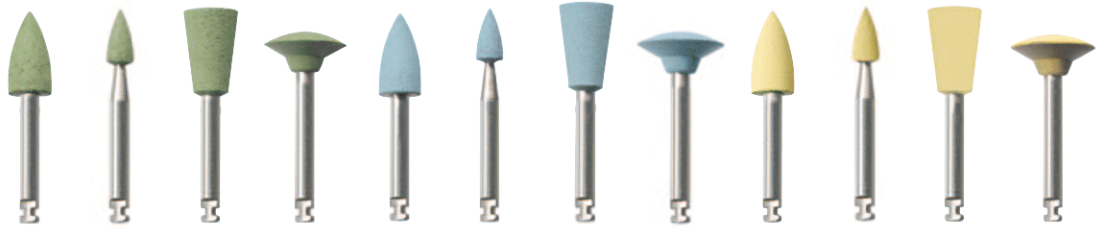

Átmérő mérete 1/10 mm	050	030	060	100	050	030	060	100	050	030	060	100
Hossz mm-ben	10,0	6,0	9,0	4,7	10,0	6,0	9,0	4,7	10,0	6,0	9,0	4,7

RA	3	REF	P332A (3)	P333A (3)	P335A (3)	P336A (3)	P3032A (3)	P3033A (3)	P3035A (3)	P3036A (3)	P30032A (3)	P30033A (3)	P30035A (3)	P30036A (3)
RA	6	REF	P332B (6)	P333B (6)	P335B (6)	P336B (6)	P3032B (6)	P3033B (6)	P3035B (6)	P3036B (6)	P30032B (6)	P30033B (6)	P30035B (6)	P30036B (6)
RA	25	REF	P332E (25)	P333E (25)	P335E (25)	P336E (25)	P3032E (25)	P3033E (25)	P3035E (25)	–	P30032E (25)	P30033E (25)	P30035E (25)	P30036E (25)
			⌚ opt. 12.000 rpm				⌚ opt. 10.000 rpm				⌚ opt. 5.000 rpm			

## CeraGlaze

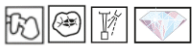

Lamellás polírozó



REF Set-1588

Átmérő mérete 1/10 mm	130	130
Hossz mm-ben	1,5	1,5

RA	6	REF	P3039B (6)	P30039B (6)
RA	100	REF	P3039G (100)	P30039G (100)
			⌚ opt. 6.000 rpm	

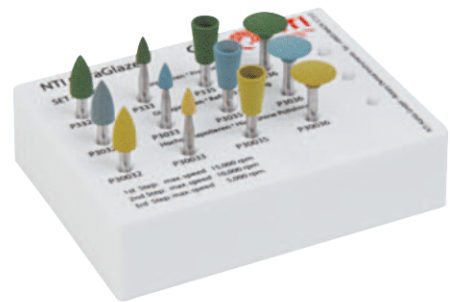

## CeraShine Duo

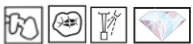

A kerámia lesimítása és a csiszolási nyomok eltávolítása



Magasfényű polírozás polírpaszta nélkül

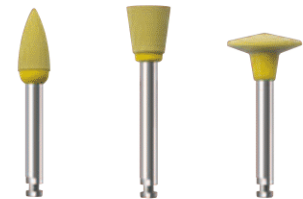

Átmérő mérete 1/10 mm	040	060	100
Hossz mm-ben	10,0	7,0	6,0

RA	6	REF	PD2530B (6)	PD2630B (6)	PD2730B (6)
RA	100	REF	PD2530G (100)	PD2630G (100)	PD2730G (100)
			⌚ opt. 10.000 rpm		

Átmérő mérete 1/10 mm	040	060	100
Hossz mm-ben	10,0	7,0	6,0

RA	6	REF	PD2540B (6)	PD2640B (6)	PD2740B (6)
RA	100	REF	PD2540G (100)	PD2640G (100)	PD2740G (100)
			⌚ opt. 10.000 rpm		

## NTI CeraDia



Különösen kemény kerámiapolírozó integrált gyémántszemcsékkel. Lágyművelő abrazív polírozás.



Átmérő mérete 1/10 mm	050	030	085	060
Hossz mm-ben	10,0	6,0	7,0	10,0

RA	6	REF	P0332B (6)	P0333B (6)	P0334B (6)	P0335B (6)
			⌚ opt. 10.000 rpm			



**CeraShine Trio**



Az új, háromlépcsős poliuretán polírozó rendszer leegyszerűsíti az összes kerámi- aanyag intraorális polírozását.

Kis, zavaró érintkezések becsiszolása

A kerámia előpolírozása és lesimítása

Magasfényű polírozás polírpassza nélkül



Átmérő mérete 1/10 mm	040	060	100	040	060	100	040	060	100
Hossz mm-ben	10,0	7,0	6,0	10,0	7,0	6,0	10,0	7,0	6,0
RA  REF	PT2520B (6)	PT2620B (6)	PT2720B (6)	PT2530B (6)	PT2630B (6)	PT2730B (6)	PT2540B (6)	PT2640B (6)	PT2740B (6)
RA  REF	PT2520G (100)	PT2620G (100)	PT2720G (100)	PT2530G (100)	PT2630G (100)	PT2730G (100)	PT2540G (100)	PT2640G (100)	PT2740G (100)

opt. 10.000 rpm



**CeraShine**

Lamellás polírozó  
Cirkónium-oxid és alumínium-oxid megmunkálásához



Átmérő mérete 1/10 mm	130
Hossz mm-ben	1,5

RA  REF	P2830B (6)
RA  REF	P2830G (100)

opt. 6.000 rpm





**CeraShine**

Lamellás polírozó  
Cirkónium-oxid és alumínium-oxid megmunkálásához



Átmérő mérete 1/10 mm	130
Hossz mm-ben	1,5

RA  REF	P2840B (6)
RA  REF	P2840G (100)

opt. 6.000 rpm



**Arany polírozó**



**NTI EpsiPol barna**  
aranyhoz, amalgámhoz és kompozitokhoz.



Átmérő mérete 1/10 mm	050	030	060	FG 030
Hossz mm-ben	10,0	6,0	10,0	6,0

RA  REF	P0032D (12)	P0033D (12)	P0035D (12)	FG P0053D (12)
RA  REF	P0032E (25)	P0033E (25)	P0035E (25)	-
RA  REF	P0032G (100)	P0033G (100)	P0035G (100)	FG P0053G (100)



opt. 5.000 rpm



**NTI EpsiPol zöld**  
aranyhoz, amalgámhoz és kompozitokhoz.  
**zöld = magasfényű politúr.**



Átmérő mérete 1/10 mm	050	030	060	FG 030
Hossz mm-ben	10,0	6,0	10,0	6,0

RA  REF	P0132D (12)	P0133D (12)	P0135D (12)	FG P0153D (12)
RA  REF	-	P0133E (25)	-	-
RA  REF	P0132G (100)	P0133G (100)	P0135G (100)	FG P0153G (100)

opt. 5.000 rpm

opt. 15.000 rpm

**Univerzális polírozó**



**NTI Uni White**  
univerzális szilikon polírozó emesfémekhez, műanyaghoz, cementhez, amalgámhoz. **Finom szemcsézet.**



Átmérő mérete 1/10 mm	050	030	060
Hossz mm-ben	10,0	6,0	10,0

RA  REF	P0532D (12)	P0533D (12)	P0535D (12)
RA  REF	P0532G (100)	P0533G (100)	P0535G (100)

opt. 5.000 rpm

**Pattanó záras kefék**



Pattanó záras – fehér, közepes



Átmérő mérete 1/10 mm	050	045
Hossz mm-ben	7,0	7,0

RA  REF	P1490G (100)	P1491G (100)
--	--------------	--------------

opt. 1.500 rpm



ProfiLax3 - Polírozó pasztával használandó.

## Teljes körű prevenció a NTI-Kahla GmbH - cégtől

A teljes körű prevenciót nyújtó rendszer három féle keménységben – bármely páciens lepedék- és fogfelszíni fogkő célirányos eltávolítására.

A keményebb kefe és polírozó az erősebb lepedék- illetve fogkő esetében alkalmazandó. A szokványos kezelések

esetében tökéletes eredményhez vezet a közepes keménységű eszköz.

A puha kefék és polírozók különösen pácienskímélők. Érzékeny páciensek esetében megkönnyítik a prevenció kezelését és biztosítják a sérült fog és íny kíméletes kezelését.

A műszerek kézre szerelve, pattanó záras- és csavaros kivitelben kaphatók.

Ez lehetővé teszi az egyedi alkalmazást.



A színek a polírozók különböző keménységi fokát jelzik.

## Profilax3



Prevenációs RA – sárga, kemény  
Prevenációs RA – fehér, közepes  
Prevenációs RA – rózsaszín, puha



Átmérő mérete 1/10 mm	060	060	060
Hossz mm-ben	10,0	10,0	10,0

RA 100 **P1242G** (100) **P1240G** (100) **P1241G** (100)

opt. 1.500 rpm



Pattanó záras – fehér, közepes  
Pattanó záras – rózsaszín, puha



Átmérő mérete 1/10 mm	060	060
Hossz mm-ben	9,2	9,2

RA 100 **P1251G** (100) **P1251G** (100)

opt. 1.500 rpm



Prevenációs csavaros – fehér, közepes  
Prevenációs csavaros – rózsaszín, puha



Átmérő mérete 1/10 mm	060	060
Hossz mm-ben	9,5	9,5

RA 100 **P1243G** (100) **P1244G** (100)

opt. 1.500 rpm

Tartó csavaros típushoz



Átmérő mérete 1/10 mm	
Hossz mm-ben	

RA 6 **M4039B** (6)  
RA 100 **M4039G** (100)

Tartó pattanó záras típushoz kehelypolírozók és polírozó kefék rögzítéséhez.



Átmérő mérete 1/10 mm	050
Hossz mm-ben	7,0

RA 6 **M4037B** (6)  
RA 100 **M4037G** (100)



## Prophylaxis polírozó



Csak vízsprayvel együtt használni!

### NTI ProphylaxeMaster

Foglepedék és elszíneződések eltávolításához. Tisztítás polírozópaszta **nélkül** is, a polírozó testbe bedolgozott eltávolító anyagok révén.



Átmérő mérete 1/10 mm	050	030	060	060	060
Hossz mm-ben	10,0	6,0	10,0	10,0	9,0

RA 12 **P1232D** (12) **P1233D** (12) **P1235D** (12) **P1238D** (12) **P1239D** (12)  
RA 100 **P1232G** (100) **P1233G** (100) **P1235G** (100) **P1238G** (100) **P1239G** (100)

opt. 5.000 rpm

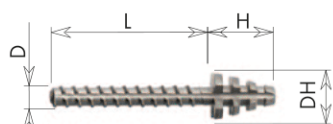
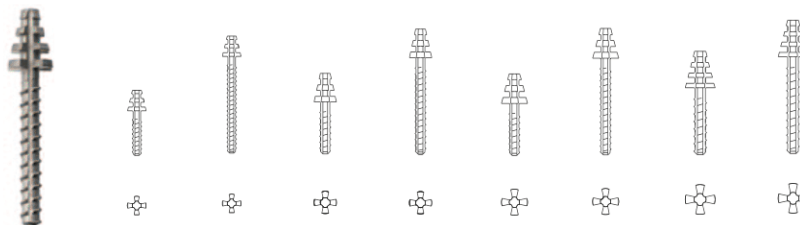
**HeadMaster kúpos fej, aktív**

**TITAN (Ti6Al4V)**

színekódolás/méret		1		2		3		4	
csapszár átmérője	D mm	1.3		1.5		1.5		1.75	
csapszár hossza	L mm	6	13	7	13	7	13	9	13
fej átmérője	DH mm	2.5	2.5	3	3	3.5	3.5	4	4
fejmagasság	H mm	2.75	2.75	3.85	3.85	4.0	4.0	4.9	4.9

10 Titan menetes csap, 1 Peeso, 1 előfúró, 1 síkcsiszoló, 1 dugókulcs

REF Készlet



W6202 W6203 W6204 W6205 W6206 W6207 W6208 W6209

10 Titan menetes csap

REF utántöltő csomag

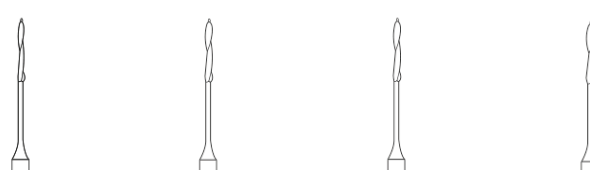
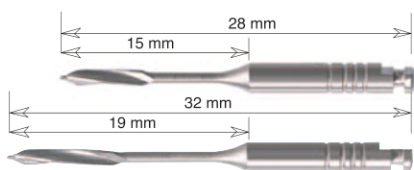
W6210 W6211 W6212 W6213 W6214 W6215 W6216 W6217

**Peeso**

szárkódolás/gyűrűk		2		3		3		4	
 REF L=15	183.15...	090		110		110		130	
 REF L=19	183.19...		090		110		110		130

opt. 800 - 1.200 rpm

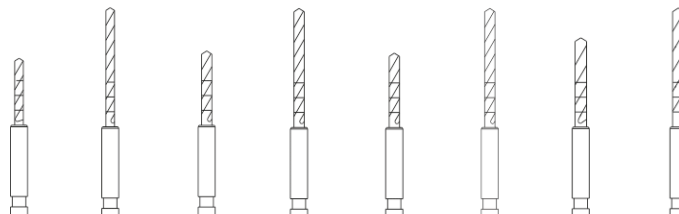
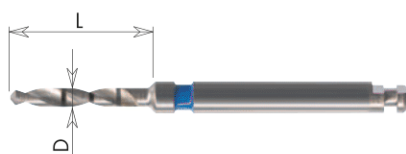
**Előfúró**

színekódolás/méret		1		2		3		4	
fúró átmérője	D mm	1.2		1.4		1.4		1.65	
fúróhossz	L mm	9	16	10	16	10	16	12	16
 REF		W6320	W6321	W6322	W6323	W6324	W6325	W6326	W6327

opt. 500 - 1.000 rpm

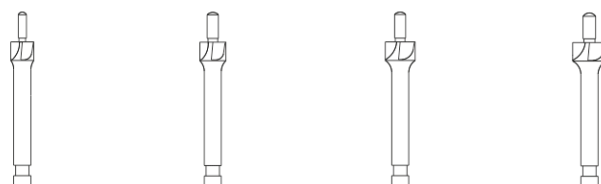
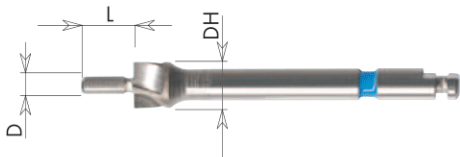
**Síkcsiszoló**

színekódolás/méret		1		2		3		4	
csap átmérője	D mm	1.1		1.3		1.3		1.55	
csaphossz	L mm	4.0		4.0		4.0		4.0	
fej átmérője	DH mm	3.0		3.5		4.0		4.5	
 REF		W6330		W6331		W6332		W6333	

opt. 1.000 - 1.500 rpm

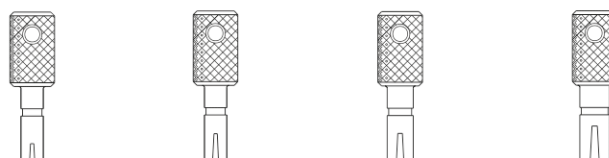
**Dugókulcs**

színekódolás/méret		1		2		3		4	
 REF		W6350		W6351		W6352		W6353	



HeadMaster hengeres fej, aktív

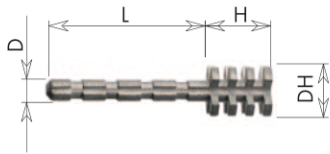

TITAN (Ti6Al4V)

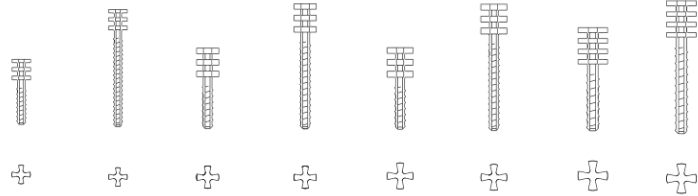

színkódolás/méret		1		2		3		4	
csapszár átmérője	D mm	1.3		1.5		1.5		1.75	
csapszár hossza	L mm	6	13	7	13	7	13	9	13
fej átmérője	DH mm	2.5	2.5	3	3	3.5	3.5	4	4
fejmagasság	H mm	2.75	2.75	3.85	3.85	4.0	4.0	4.9	4.9

10 Titan menetes csap, 1 Peeso, 1 előfúró, 1 síkcsiszoló, 1 dugókulcs

REF **Készlet** W6402 W6403 W6404 W6405 W6406 W6407 W6408 W6409

10 Titan menetes csap

REF **utántöltő csomag** W6410 W6411 W6412 W6413 W6414 W6415 W6416 W6417

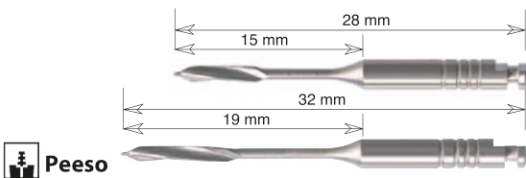

Peeso

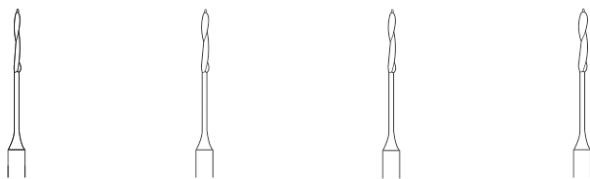

szírkódolás/gyűrűk		2		3		3		4	
--------------------	--	---	--	---	--	---	--	---	--

REF **L=15** 183.15... 090 110 110 130

REF **L=19** 183.19... 090 110 110 130

opt. 800 - 1.200 rpm

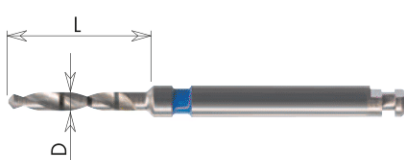

Előfúró

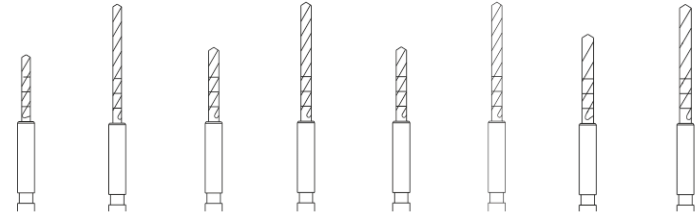

színkódolás/méret		1		2		3		4	
-------------------	--	---	--	---	--	---	--	---	--

fúró átmérője	D mm	1.2		1.4		1.4		1.65	
fúróhossz	L mm	9	16	10	16	10	16	12	16

REF W6320 W6321 W6322 W6323 W6324 W6325 W6326 W6327

opt. 500 - 1.000 rpm

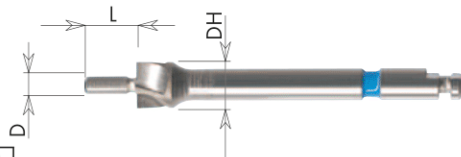

Síkcsiszoló

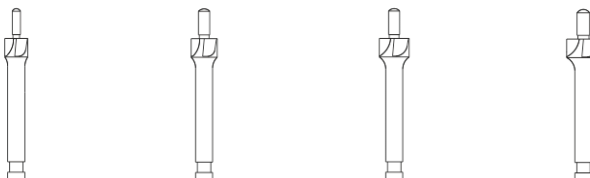

színkódolás/méret		1		2		3		4	
-------------------	--	---	--	---	--	---	--	---	--

csap átmérője	D mm	1.1		1.3		1.3		1.55	
csaphossz	L mm	4.0		4.0		4.0		4.0	
fej átmérője	DH mm	3.0		3.5		4.0		4.5	

REF W6330 W6331 W6332 W6333

opt. 1.000 - 1.500 rpm



Dugókulcs

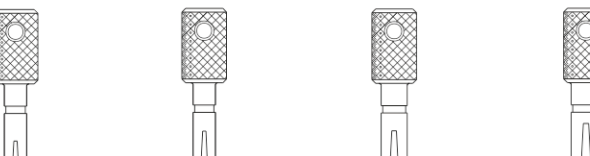

színkódolás/méret		1		2		3		4	
-------------------	--	---	--	---	--	---	--	---	--

REF W6350 W6351 W6352 W6353

## Ajánlott fordulatszám tartományok

☺ max. Ezen adat adja meg a maximális fordulatszámot a munkadarab érintése nélkül.

☺ opt. Ezen adat adja meg az optimális fordulatszámot a munkadarab érintésekor.

### FG Gyémánt csiszolóeszközök

Fordulatszámajánlatok az **M, SC** és **C** szemcsézetekhez

A munkadarab átmérője (ISO)

	☺ opt./ rpm	☺ max./ rpm
007 – 010	100.000 – 220.000	450.000
012 – 015	70.000 – 220.000	450.000
016 – 019	55.000 – 160.000	450.000
020 – 024	40.000 – 120.000	300.000
025 – 027	35.000 – 110.000	160.000
029 – 031	30.000 – 95.000	140.000
033 – 040	25.000 – 75.000	120.000
041 – 050	15.000 – 60.000	95.000

Feltétlenül figyelembe kell venni a speciálisan megjelölt eszközök esetében a fordulatszám tartományokat: **M, SC, C**

1	70.000 – 140.000	300.000
2	40.000 – 85.000	160.000
3	30.000 – 60.000	140.000

Fordulatszámajánlatok az **F, SF** és **UF** szemcsézetekhez

F	10.000 – 20.000	40.000
SF	8.000 – 15.000	30.000
UF	5.000 – 10.000	20.000

### Z-Cut Gyémánt csiszolóeszközök

**LazyBur**

**RA - szár**

Fordulatszámajánlatok a következő szemcsézetekhez **M, SC, C, F**

	200.000	200.000	
	30.000 – 95.000	140.000	
			8.000
	<b>SF</b>	8.000	30.000
	<b>UF</b>	8.000	20.000
Gyermekfogászati fúrók - a minimal invazív kezeléshez	160.000	300.000	

### Keményfém fúrók

		☺ opt./ rpm	☺ max./ rpm
FG	MF-Cut	60.000	160.000
FG	MF-Cut	160.000	300.000
RA	MF-Cut	005 - 023	5.000 - 40.000
RA	MF-Cut	029	5.000 - 30.000
FG/FGXL	H1S / H1SX	006 - 016	160.000
FG/FGXL	H1S / H1SX	018 - 023	160.000
RA/RAL	H1S / H1SX	8.000 - 10.000	40.000
RA/RAL	H1SXN	1.000 - 1.500	10.000
RA	H1SF	1.500 - 2.000	50.000

### Keményfém finírozók

FG	Egylépcsős polírozó	20.000	300.000
FG		160.000	300.000
RA		30.000	40.000
	H375R	> 016	160.000

### Kerámia finírozók

FG		150.000	200.000
----	--	---------	---------

### Koronafelvágók

FG	H34/H34L	160.000	300.000
FG	H4KMK	160.000	300.000
FGL	H4KMKL	160.000	300.000
RA	G5114-RA	10.000	10.000

### Tömés- és ragasztóanyag eltávolítók

FG		160.000	300.000
RA		30.000	40.000

## Ajánlott fordulatszám tartományok

Az ajánlott fordulatszámok a munkadarabok átmérőjéhez illeszkednek és optimális munkaeredményt tesznek lehetővé. Biztonsági okokból a maximális fordulatszámot nem szabad túllépni.

<b>Endodonciás eszközök</b>		opt./ rpm	max./ rpm
NTi Endo Clean		300	300
H152	009	120.000	120.000
802L	013 - 016	120.000	200.000
802L	021	160.000	200.000
H15NL		1.500 - 2.000	12.000

**Figyelem: Csak a piros sarokelemben használható**

<b>Tissue Trimmer</b> 249-016-FG, 250-016-FG	300.000 - 500.000	500.000
--	-------------------	---------

<b>Sebészeti eszközök</b>		opt./ rpm	max./ rpm
HP/HPL/RAL/RAXL	≤ 023	1.500	3.000
	023 - 035	1.500	3.000
	> 035	1.500	3.000
FGXXL	008	100.000	160.000
FGXL/FGXXL	010	100.000	160.000
FGXL	012 - 014	100.000	160.000
FGXL/FGXXL	016 - 018	75.000	160.000
FGXL	021 - 023	50.000	160.000
FGXL/FGXXL	H254A	80.000	100.000
HP/RAL/RAXL	H254A	40.000	100.000
<b>LINDEMANN csontfűrők</b>			
HP/RAL/RAXL		1.500	3.000
FGXL	RF162-016-FGXL	75.000	160.000
FGXL	H161-016-FGXL	100.000	160.000
FGXL	H162-016-FGXL	100.000	160.000
NTI ChirDia FG	Compacta	100.000	200.000
NTI ChirDia RA	Compacta	20.000	40.000
NTI ChirDia HP	Compacta	10.000 - 30.000	40.000
NTI ChirDia FG	Spongiosa	30.000	200.000
NTI ChirDia HP/RA	Spongiosa	10.000	40.000

**FG Figyelem: Csak a piros sarokelemben használni**

<b>Polírozó</b>		opt./ rpm	max./ rpm
DiaGloss	rózsaszín / fehér	10.000	12.000
DiaGloss Lamellás polírozó		6.000	8.000
Unique		5.000	12.000
Unique Lamellás polírozó		5.000	7.000
CeraGlaze	zöld	12.000	12.000
	kék	10.000	12.000
	sárga	5.000	12.000
CeraGlaze Lamellás polírozó		6.000	8.000
CeraShine Duo / CeraShine Trio		10.000	12.000
CeraGlaze Lamellás polírozó		6.000	8.000
NTI CeraDia RA		10.000	10.000
NTI Uni White RA		5.000	7.000
RA EpsiPol barna / EpsiPol zöld		5.000	7.000
FG EpsiPol barna/zöld P0053, P0153		15.000	15.000
ProphylaxeMaster		5.000	5.000
FlexiPol		10.000-12.000	15.000
NTI Brush Gloss / RA Composite P1500, P1501, P1502		3.000	5.000
Prevenációs polírozók RA		1.500	10.000
Profilax		2.000	10.000
Prevenációs kefék		2.000	10.000
Csavaros kefék		1.500	10.000
Pattanó záras kefék		1.500	10.000
P1258		2.000	10.000
<b>Gyökércsap - felépítőrendszerek</b>			
Kibővített	W6196.204. ...	500 - 1.000	1.000
W6130.204. . / Síkmaró		1.000 - 1.500	2.000
Előfűrő		500 - 1.000	1.000